

“A” Series Variable Displacement Piston Pumps

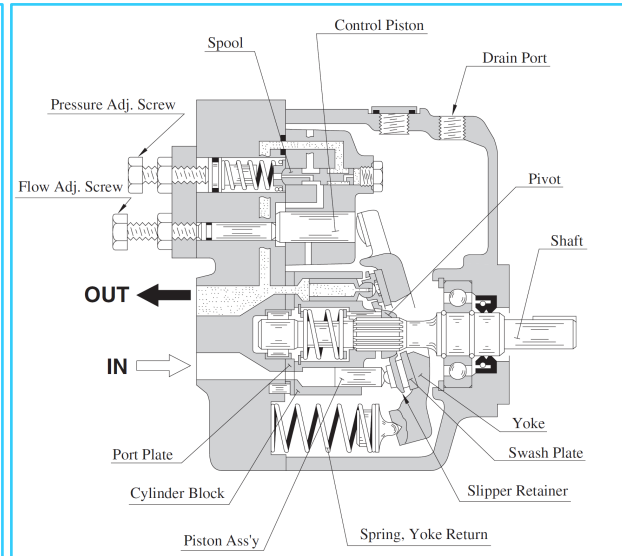
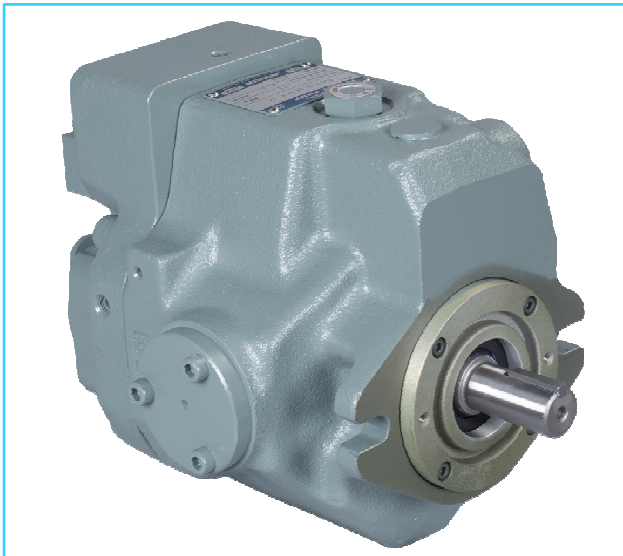

Features

- **High efficiency**
Under the conditions of pressure 160 Kgf/cm² and speed 1800 r/min. volumetric efficiency is over 98% and the overall efficiency is over 90%.

- **Low noise level**
In the “A16” pump, the noise level is as low as 57.3dB(A) [At the full cut-off pressure 210 Kgf/cm² with speed 1500 r/min. at one meter horizontally away from pump head cover.]

“A16” Type performance characteristics

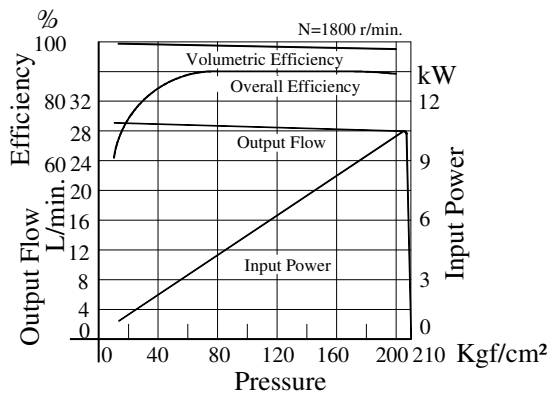

“A16” Type Noise level characteristics

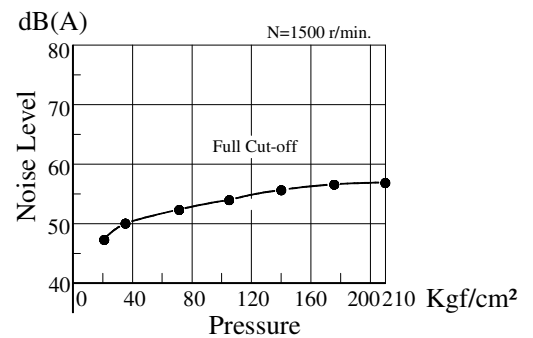

- **Accomplishment of energy saving**
Because the overall efficiency is high and the cut-off characteristics is sharp, thus the input power may be saved.

- **Low heat generation**
Because of small power loss, it is possible to reduce the rise in oil temperature. Accordingly, capacity of a reservoir can be reduced

Instructions

Hydraulic Fluids.

Use petroleum base oil such as anti-wear type hydraulic oils or R & O (Rust and oxidation inhibitor) type hydraulic oils (ISO VG 32 or 46) with a viscosity range of 20 to 400 cSt at temperature of 0-60°C both to be satisfied.

Control of contamination.

Much care should be taken to maintain control over contamination of the operating oil which can otherwise lead to breakdown and shorten the life of the unit. Please maintain the degree of contamination within NAS Grade 10.

The suction port must be equipped with at least a 100 μm (150mesh) reservoir type filter and the return line must have a line type filter of under 10μm.

Mounting

When installing the pump the filling port should be positioned upwards.

Alignment of Shaft.

Employ a flexible coupling whenever possible, and avoid any stress from bending thrust. Maximum permissible misalignment is less than 0.1 mm TIR and maximum permissible misangularity is less than 0.2°.

Suction Pressure.

Permissible suction pressure at inlet port of the pump is between -0.16 and +0.5 Kg_f/cm² (-125 mm Hg~+0.5 Kg_f/cm²). For piping to the suction port, use pipes of the same diameter as that of the specified pipe flange. Make sure that the height of the pump inlet port is within one meter from the oil level in the reservoir.

Hints on Piping.

When using steel piping for the suction of discharge ports, excessive load from the piping on the pump generates excessive noise. Whenever there is fear of excessive load, please use rubber hoses.

Suction Piping.

In case the pump is installed above the oil level, the suction piping and suction line filter should be located lower than the pump position to prevent air in the suction line.

Drain Piping.

Install drain piping according to the chart and ensure that pressure within the pump housing should be maintained at a normal Pressure of less than 1 Kg_f/cm² and surge pressure of less than 5 Kg_f/cm².

Length of piping should be less than 1 m, and the pipe end should be submerged in oil.

Recommended Drain Piping Size.

- Fix drain pipe for each side of the pump

Model Number	Fitting Size	Inside Dia. Of Pipe
A Series		
A10,A16,A22	3/8 (Inside dia. 8.5 mm or more)	ø 10 mm
A37	1/2 (Inside dia. 12 mm or more)	ø 12 mm
A56,A70 A90,A145	3/4 (Inside dia. 16 mm or more)	ø 19 mm

Bleeding Air.

It may be necessary to bleed air from pump case and outlet line to remove causes of vibration. An air bleed valve (Model No. ST1004-※-1080) is recommended for this purpose.

Starting.

Before starting, first time fill the pump case with clean operating oil through the fill port. In order to avoid air blockage, when first starting, adjust the control valves so that the discharged oil from the pump is returned directly to the tank or the actuator moves in a free load.

[Volume of Pre-Fill Oil Required]

Model Number	Volume cm ³
A Series	
A10	370
A16,A22	600
A37, A56	1200
A70	2100
A90	2500
A145	3300

■ **Setting Discharge Pressure and Delivery**

At the time of despatch, the unit has been preset to the maximum delivery and minimum discharge pressure. Adjust the preset delivery and pressure to meet your system requirements.

● **Adjustment of Discharge Pressure**

Turning the adjustment screw clockwise, increases pressure.

[Pressure adjusted by each one turn of the pressure adjustment screw]

Model Numbers	Adjustment Pressure Kgf/cm ²
A10-FR01B	29.6
A10-FR01C/H	55.1
A16/A22/A37/A56-※-R-01-B	35.7
A16/A22/A37/A56/-※-R-01-C	66.3
A16/A37/A56/-※-R-01-H	80.6
A70/A90/A145-※-R01B	23.4
A70/A90/A145-※-R01C	32.6
A70/A90/A145-※-R01H	40.8
A70/A90/A145-※-R01K	47.9

● **Adjustment of Delivery**

Turning the delivery adjustment screw clockwise, decreases delivery.

Lock the screw after adjustment.

[The minimum adjustable flow and adjustable volume of each full turn of the delivery adjustment screw]

Model Numbers	Adjustable Volume with each full turn of the adjustment screw cm ³ /rev.	Minimum adjustable flow cm ³ /rev.
A10	1.1	2
A16	1.4	4
A22	2	6
A37	2.9	10
A56	3.9	12
A70	4.4	30
A90	4.8	56
A145	7.2	83

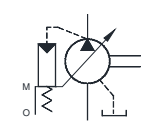
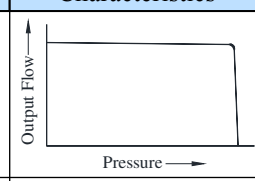
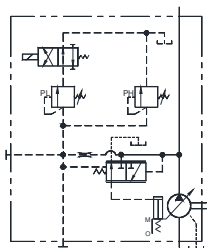
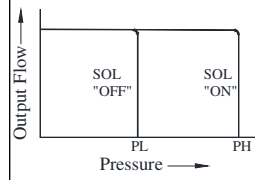
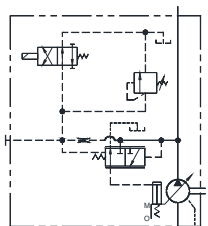
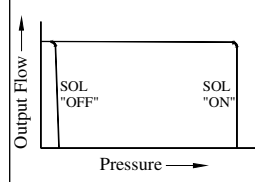
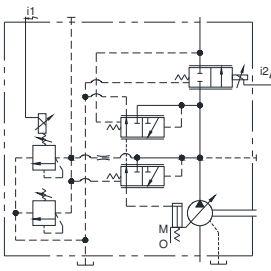
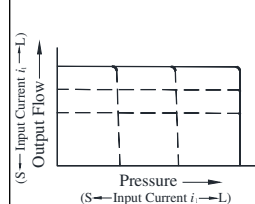
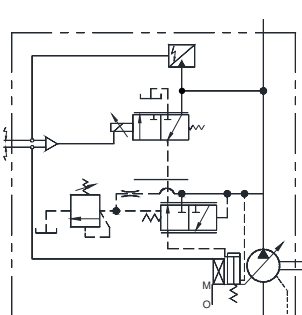
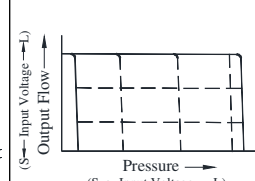
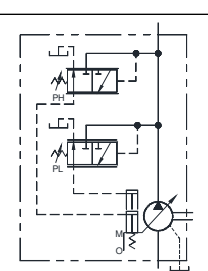
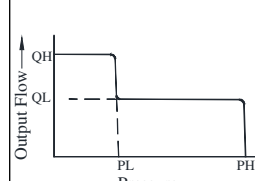
Control Type	Graphic Symbols	Performance Characteristics	Explanation	Page
“01” Pressure compensator type			When the system pressure increases and comes close to the preset cut-off pressure, the pump flow decreases automatically while maintaining the set pressure as it is.	6
“02” Solenoid-two pressure control type			This type of control is ideal for an application where the output power of the actuator has to be controlled in two different load pressures while keeping the actuator speed nearly constant.	*
“03” Pressure compensator with unloading type			It is suitable for a situation where a long unloading time is required and heat generation and noise have to be kept at their lowest levels. The pump can use in combination with the multistage pressure control valve.	*
“04” Proportional electro hydraulic load sensing type			This is an energy saving type control which regulates the pump flow and load pressure to be at absolute minimum necessary level to operate the actuator. Pump flow rate and cut of pressure are controlled proportional to the input current to the control device on the pump and the input current is regulated by the specific amplifier.	20
“04E” Proportional electro hydraulic pressure & flow control type			This type of control has the pressure sensor and tilt angle sensor in the pump. The pump is used with the external amplifier. Flow and pressure can be controlled in proportion to input voltage by only one control valve. The feature has been greatly improved by electrical feedback of swash plate tilt angle correspond to flow rate and load pressure to control valve. <ul style="list-style-type: none"> • Linearity of input characteristics is excellent and easy to set. • Hysteresis is lower, repeatability and reproducibility are fine 	30
“05” Two-pressure two-flow control type by system pres.			This type of control is suitable for an application like “presses” where the changeover from rapid advance to feed is required just when the pressing (pressurizing) starts	*

Control Type	Graphic Symbols	Performance Characteristics	Explanation	Page
"06" Two-pressure two-flow control type by solenoid valve			This pump control is suitable for machining found on machine tool, where machining starts after the changeover from rapid advance, to feed has been made.	*
"07" Pilot pressure control type pressure compensator			The pump is used in combination with the pilot relief valve or multistage pressure control valve. By controlling the pilot pressure, the full cut-off pressure can be remote-controlled according to the requirements.	*
"09" Constant power control type			<ul style="list-style-type: none"> • Pump input power can be controlled in accordance with the motor output. • When the discharge pressure raises, the output flow decreases corresponding to the preset input power. • The pump can act for function of 2 pumps, low pressure large-flow and high-pressure small-flow. Therefore, the motor capacity can be reduced. 	*

* Control Type "01", "04" & "04E" are shown in catalogue. Contact yuken for the details of other control type

■ Availability of Control Type

Mark "O" in the table below refers to standard model.

Model Numbers	Geometric Displacement cm ³ /rev.	Control Type								
		01	02	03	04	04E	05	06	07	09
A10	10.0	O							O	
A16	15.8	O	O	O	O	O	O	O	O	O
A22	22.2	O	O	O	O	O		O	O	
A37	36.9	O	O	O	O	O	O	O	O	O
A56	56.2	O	O	O	O	O	O	O	O	O
A70	70.0	O	O	O	O	O		O	O	O
A90	91.0	O	O	O	O	O		O	O	
A145	145.0	O	O	O	O	O		O	O	O

**“A” Series Variable Displacement Piston Pumps-Single Pump,
Pressure Compensator Type**

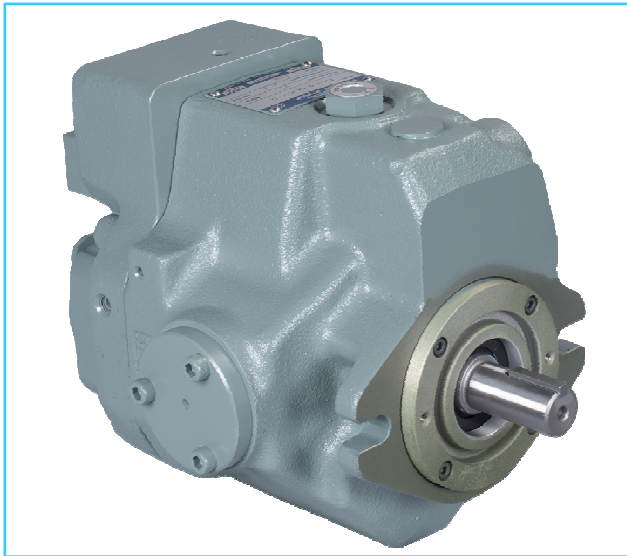

Graphic Symbol



Specifications

Model Numbers	Geometric Displacement cm ³ /rev.	Minimum Adj. Flow cm ³ /rev	Operating Pressure Kgf/cm ²		Shaft Speed Range r/min.		Approx. Mass Kg.	
			Rated ^{*2}	Intermittent ^{*1}	Max.	Min.	Flange Mtg.	Foot Mtg.
A10-FR01B-12	10.0	2.0	160	210	1800	600	5.1	-
A10-FR01C/H-12							8.5	
A16-※-R-01-※-※-K-32	15.8	4	160	210	1800	600	16.5	18.7
A22-※-R-01-※-※-K-32	22.2	6	160	160	1800	600	16.5	18.7
A37-※-R-01-※-※-K-32	36.9	10	160	210	1800	600	28.0	32.3
A56-※-R-01-※-※-K-32	56.2	12	160	210	1800	600	35.0	39.3
A70-※R01※S-60	70.0	30	250	280	1800	600	58.5	70.5
A90-※R01※S-60	91.0	56	250	280	1800	600	72.5	93
A145-※R01※S-60	145.0	83	250	280	1800	600	92.5	117.5

- *1 Whenever setting pressure, make sure the full cut off pressure never exceeds the maximum intermittent pressure.
- *2 Care should be taken when used at a higher pressure instead of rated pressure, because operating terms may be restricted. For example, if used as per maximum illustrated operating conditions, intermittent time at maximum flow is restricted to under 1/5 of one cycle time and under 6 seconds simultaneously. Conditions may vary according to the actual working pressure and delivery (inclination angle of swash plat). Consult factory or Yuken sales representative for further information.

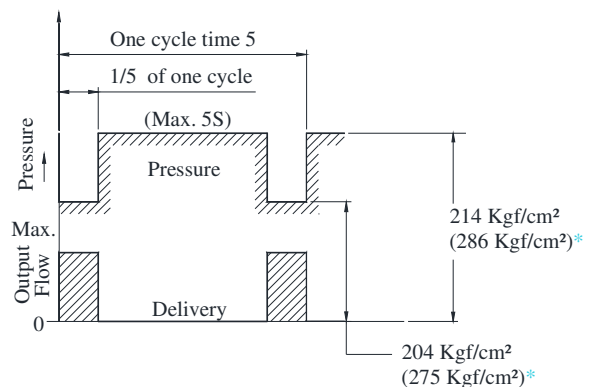

Model Number Designation

A16	-F	-R	-01	-B	-S	-K	-32
Series Number	Mounting	Direction of Rotation	Control Type	Pres. Adj. Range Kg/cm ²	Port Position	Shaft Extension	Design Number
A16 (15.8 cm ³ /rev.)	F: Flange Mounting	(Viewed from shaft end) R: Clockwise (Normal) ^{*1}	01: Pressure Compensator Type	B: 12.2 ~ 71.4 C: 12.2 ~ 163 H: 12.2 ~ 214	None: Axial Port	K: Keyed Shaft	32
A22 (22.2 cm ³ /rev.)				B: 12.2 ~ 71.4 C: 12.2 ~ 163			
A37 (36.9 cm ³ /rev.)	L: Foot Mounting			B: 12.2 ~ 71.4 C: 12.2 ~ 163 H: 12.2 ~ 214	S: Side Port		
A56 (56.2 cm ³ /rev.)							

A70	-F	R	01	B	S	-60
Series Number	Mounting	Direction of Rotation	Control Type	Pres. Adj. Range Kg/cm ²	Port Position	Design Number
A10 (10.0 cm ³ /rev.)	F: ^{*2} Flange Mounting	(Viewed from shaft end) R: Clockwise (Normal) ^{*1}	01: Pressure Compensator Type	B: 12.2 ~ 71.4 C: 12.2 ~ 163 H: 12.2 ~ 214	-----	12
A70 (70.0 cm ³ /rev.)	F: Flange Mounting			B: 12.2 ~ 71.4 C: 15.3 ~ 163 H: 18.4 ~ 214	S: Side Port	
A90 (91.0 cm ³ /rev.)				L: Foot Mounting		K: 20.4 ~ 286
A145 (145 cm ³ /rev.)						60

*1 Available to supply pump with anti-clockwise rotation. Consult Yuken for details.

*2 When A10 pump is to be used as the foot mounting, order the mounting bracket kit shown below separately. Ref. to the page 18 for dimensions of the mounting bracket.

Note: The mounting bracket-kit consists of Mounting Bracket, 2 hex. Bolts and 2 Plain Washers.

Mounting Bracket Kit Numbers	Approx. Mass Kg.
LP-1A-10	2.2

Pipe Flange Kits.

Pipe flange kits are available. When ordering, specify kit number from the table below.

Pump Model Numbers	Port Name	Pipe Flange Kit Numbers. ^{*1}	
		Threaded Connection	Socket Welding
A16-※-R-01	Suction	F5-06-A-1080	F5-06-B-10
A22-※-R-01	Discharge	F5-06-A-1080	F5-06-B-10
A37-※-R-01	Suction	F5-10-A-1080	F5-10-B-10
A56-※-R-01	Discharge	F5-10-A-1080	F5-10-B-10
A70-※ R01	Suction	F5-12-A-1080	F5-12-B-10
	Discharge	F5-08-A-1080	F5-08-B-10
A90-※ R01	Suction	F5-16-A-1080	F5-16-B-10
A145-※ R01	Discharge	F5-10-A-1080	F5-10-B-10

*1 Details of pipe flange kits are described in EIC-L-1001.

Typical Performance Characteristics of Type "A10" Oil Viscosity 20cSt [ISO VG 32, 50° C]

Performance Characteristic Curve

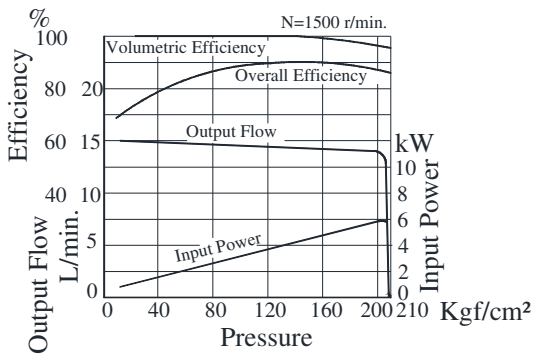

Input Power

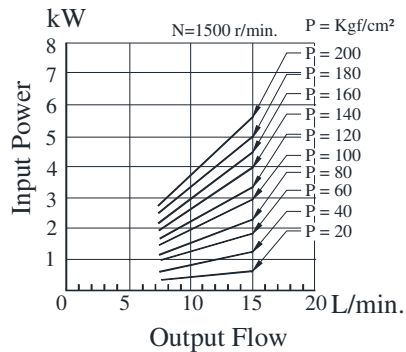

Full Cut-off Power

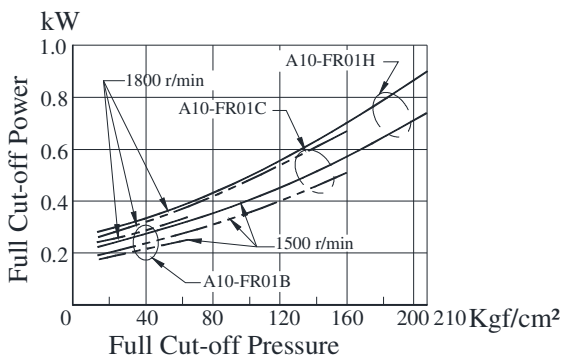

Noise Level

[One meter horizontally away from pump head cover]

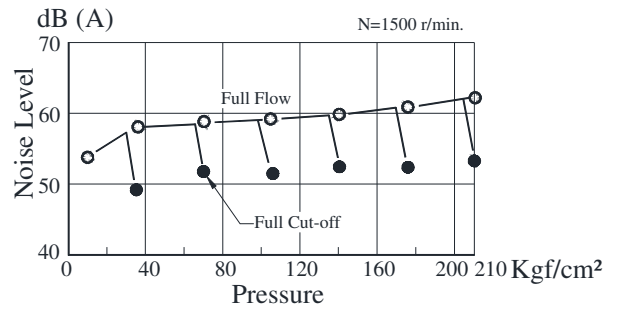

Drain

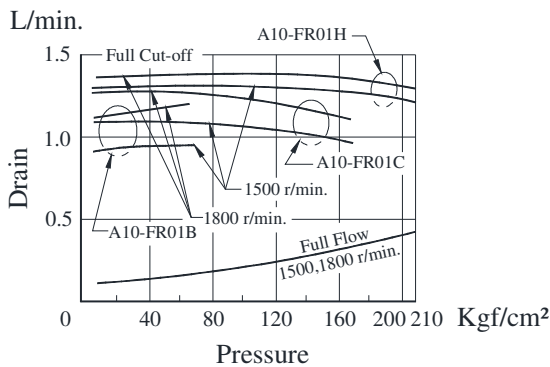

Typical Performance Characteristics of Type "A16" Oil Viscosity 20cSt [ISO VG 32, 50° C]

Performance Characteristic Curve

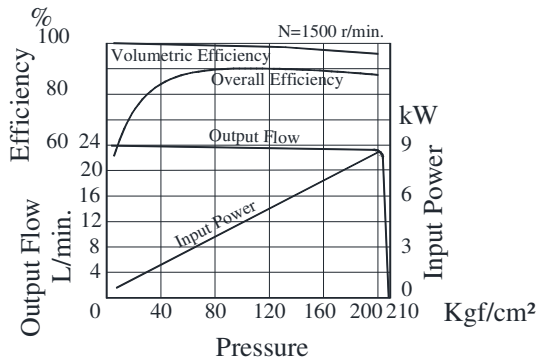

Input Power

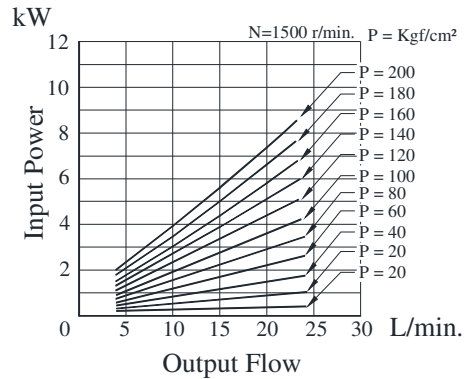

Full Cut-off Power

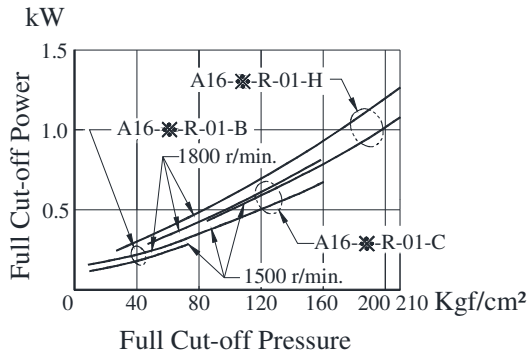

Noise Level

[One meter horizontally away from pump head cover]

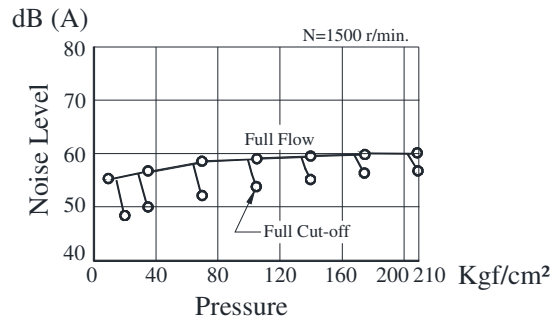

Drain

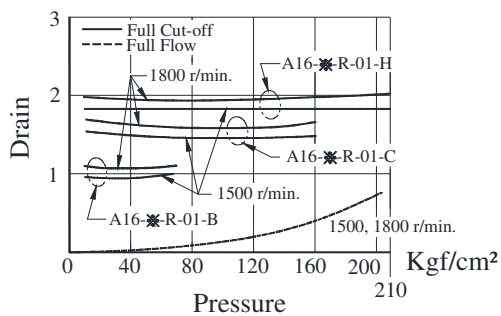

Typical Performance Characteristics of Type "A22" Oil Viscosity 20cSt [ISO VG 32, 50° C]

Performance Characteristic Curve

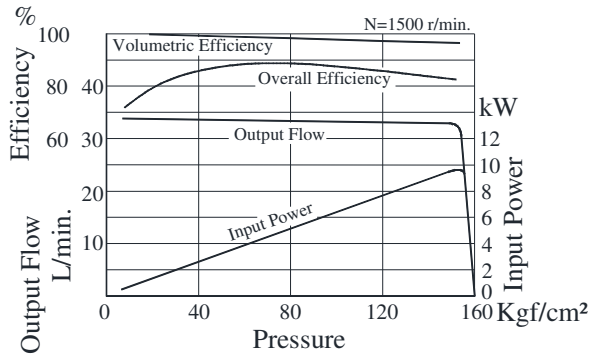

Input Power

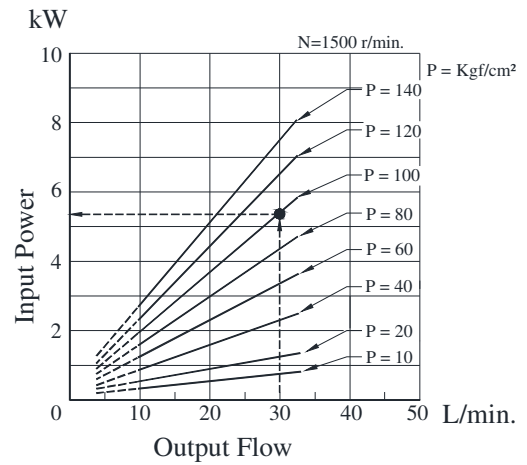

Full Cut-off Power

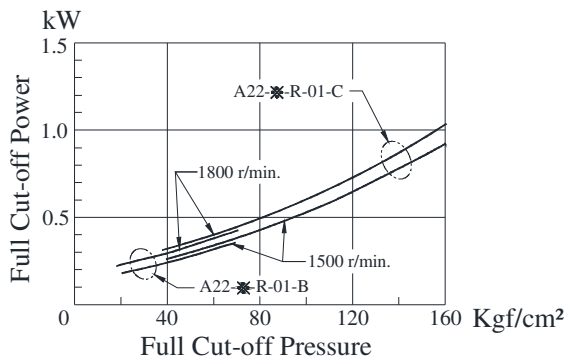

Noise Level

[One meter horizontally away from pump head cover]

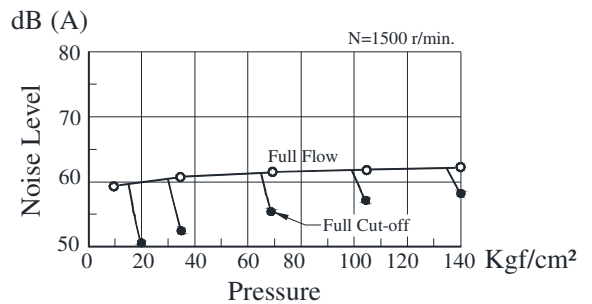

Drain

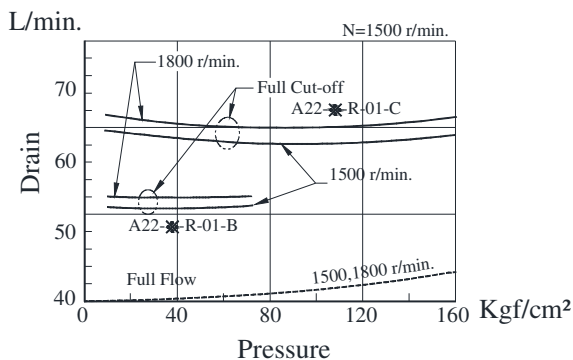

Typical Performance Characteristics of Type "A37" Oil Viscosity 20cSt [ISO VG 32, 50° C]

A

"A" Series Variable Displacement Piston Pumps

Performance Characteristic Curve

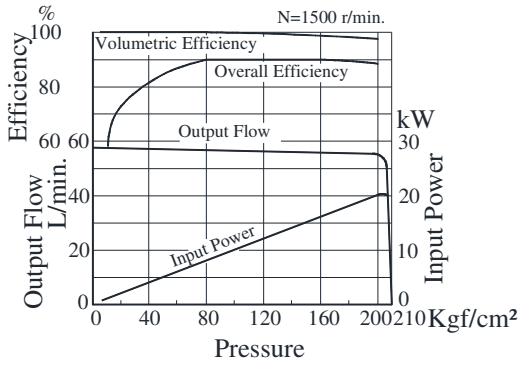

Input Power

Example: At a pressure of 160 Kgf/cm², Flow 45 L/min. & speed 1500 r/min. the shaft input is about 12.6kW. as shown the dotted line in the graph

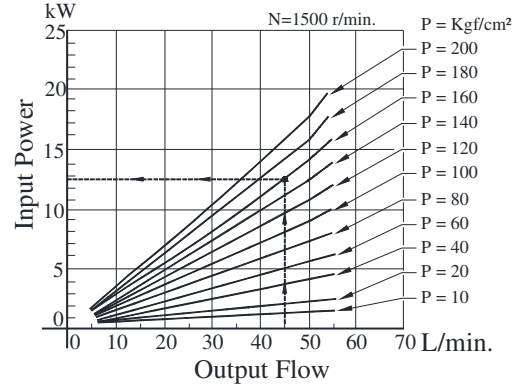

Full Cut-off Power

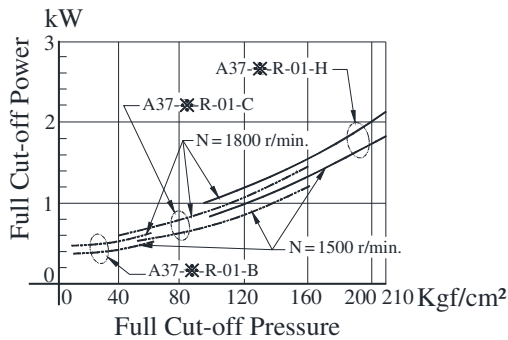

Noise Level

[One meter horizontally away from pump head cover]

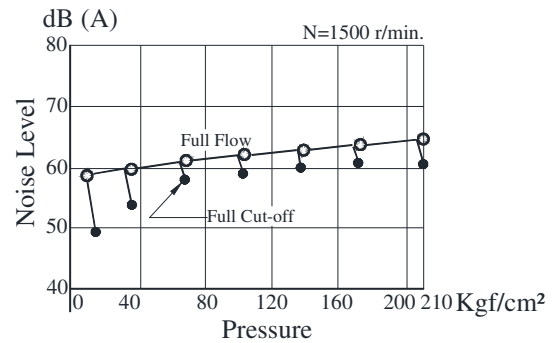

Drain

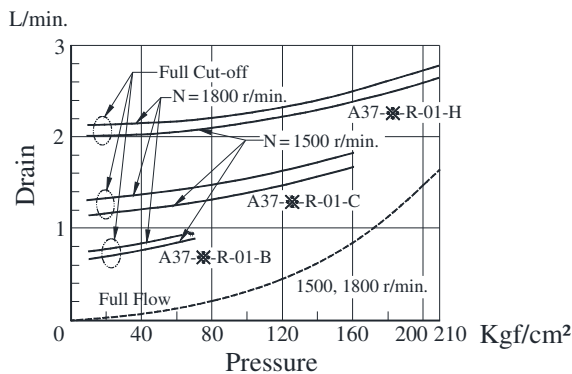

Typical Performance Characteristics of Type "A56" Oil Viscosity 20cSt [ISO VG 32, 50° C]

Performance Characteristic Curve

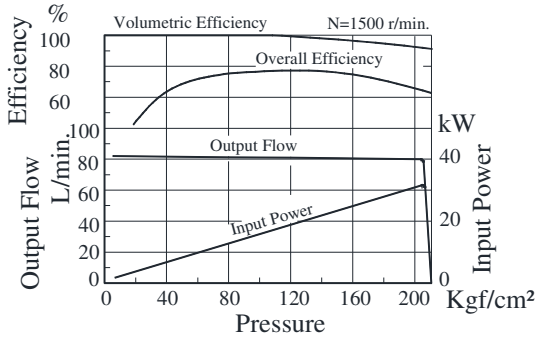

Input Power

Example: At a pressure of 160 Kg/cm², Flow 70 L/min. & speed 1500 r/min. the shaft input is about 20.8kW. as shown the dotted line in the graph

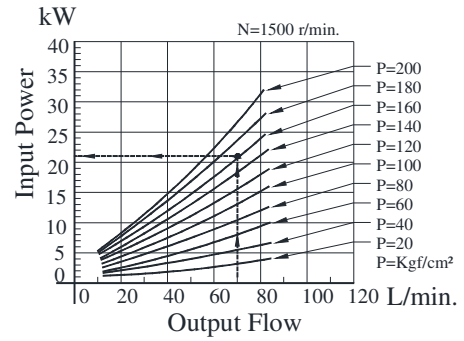

Full Cut-off Power

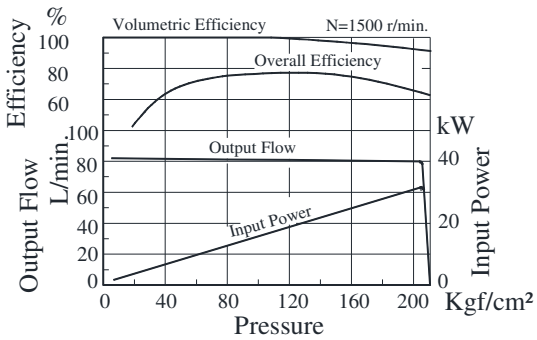

Noise Level

[One meter horizontally away from pump head cover]

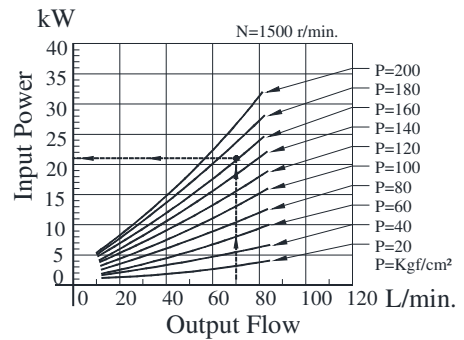

Drain

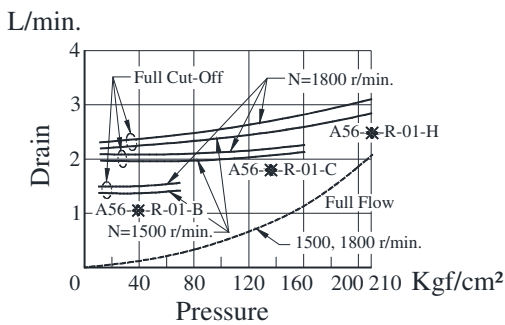

Typical Performance Characteristics of Type "A70" Oil Viscosity 32cSt [ISO VG 32, 50° C]

Performance Characteristic Curve

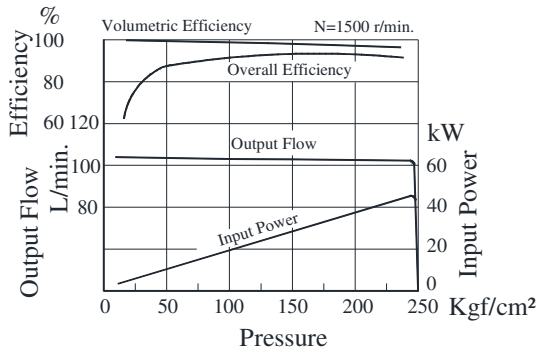

Input Power

Example: At a pressure of 200 Kg/cm², Flow 70 L/min. & speed 1500 r/min. the shaft input is about 26kW. as shown the dotted line in the graph

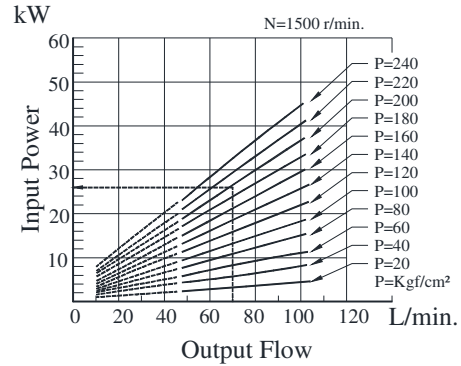

Full Cut-off Power

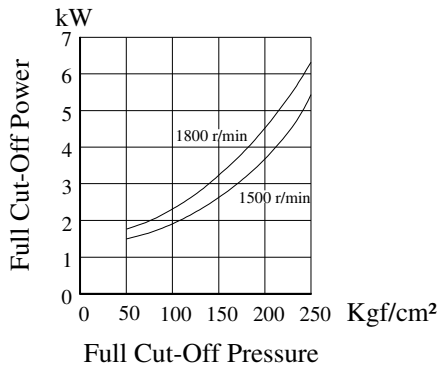

Noise Level

[One meter horizontally away from pump head cover]

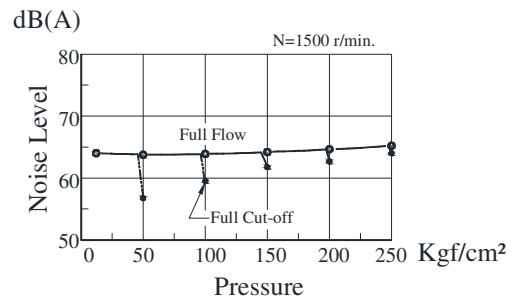

Drain

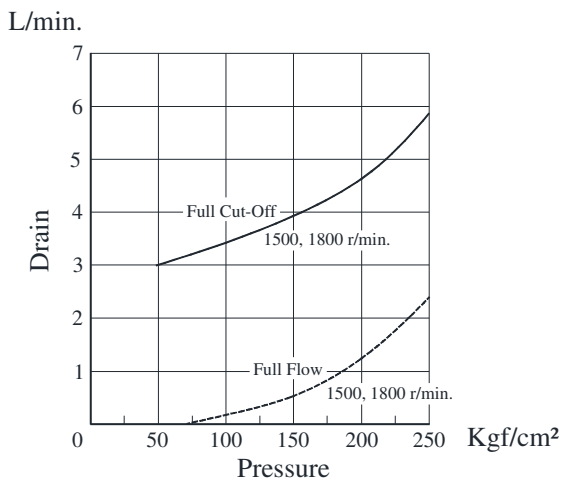

Typical Performance Characteristics of Type "A90" Oil Viscosity 32cSt [ISO VG 32, 50° C]

Performance Characteristic Curve

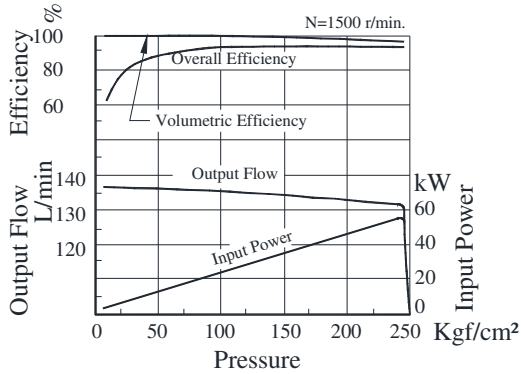

Input Power

Example: At a pressure of 180 Kgf/cm², Flow 110 L/min. & speed 1500 r/min. the shaft input is about 34kW. as shown the dotted line in the graph

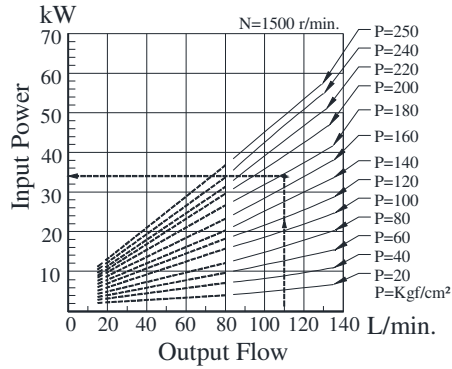

Full Cut-off Power

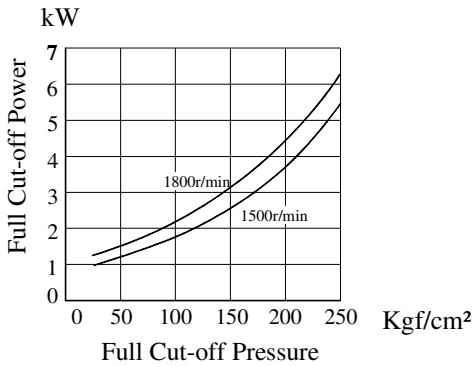

Noise Level

[One meter horizontally away from pump head cover]

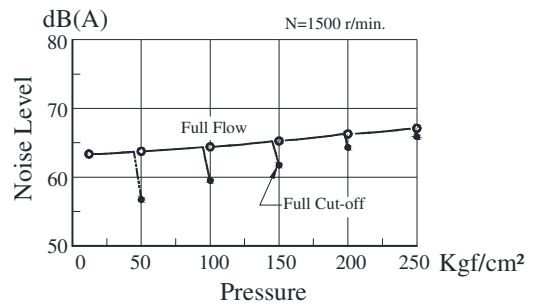

Drain

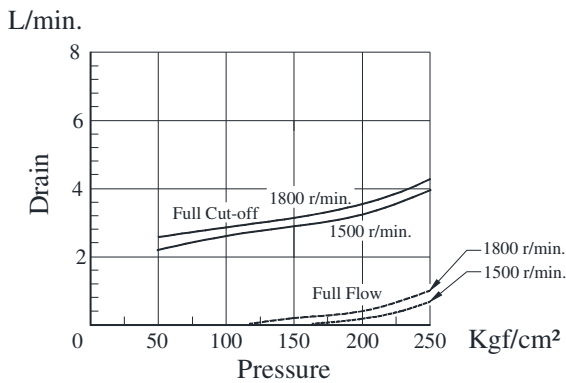

Typical Performance Characteristics of Type "A145" Oil Viscosity 32cSt [ISO VG 32, 50° C]

A

"A" Series Variable Displacement Piston Pumps

Performance Characteristic Curve

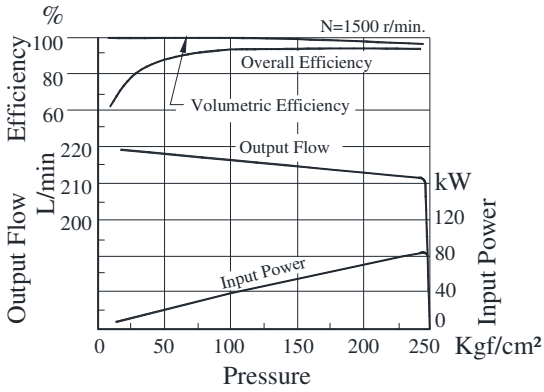

Input Power

Example: At a pressure of 200 Kgf/cm², Flow 180 L/min. & speed 1500 r/min. the shaft input is about 60kW. as shown the dotted line in the graph

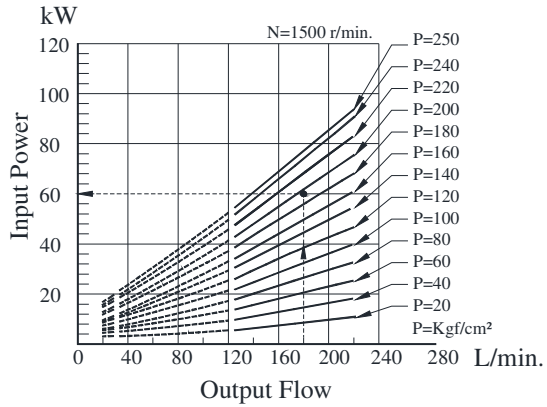

Full Cut-off Power

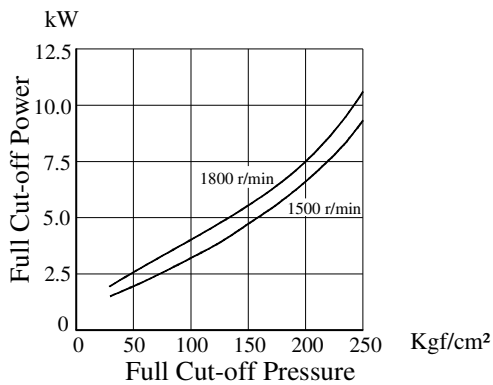

Noise Level

[One meter horizontally away from pump head cover]

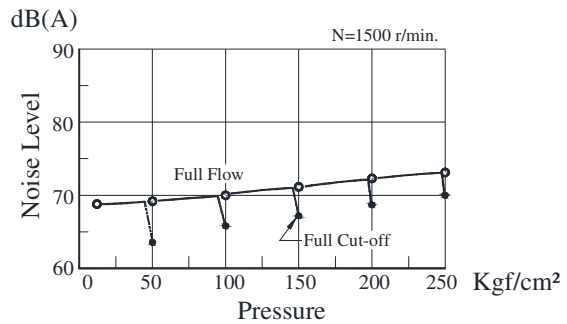

Drain

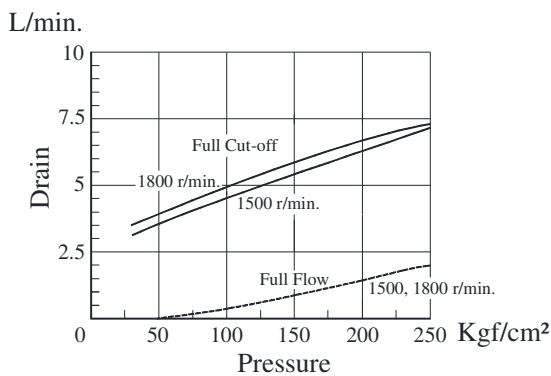

A10-FR01^C_H-12

● **Flange Mounting**

DIMENSIONS IN MILLIMETRES

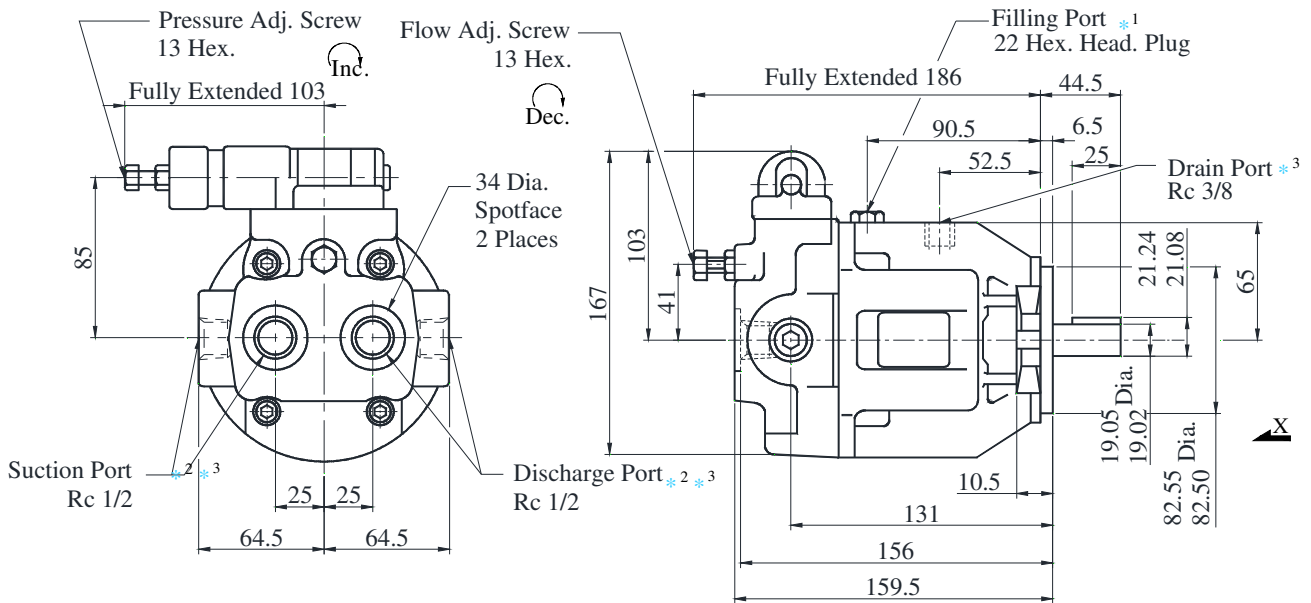

- *1 Install the pump so that the “Filling Port” is at the top.
- *2 Use either port of two suction and discharge ports at your option. keep the remaining ports plugged.
- *3 As the tightening torques of suction, discharge and drain port fittings, conform to the below.

Model Numbers	Tightening Torque Kgf-m	
	Suction Port & Discharge Port	Drain Port
A10-FR01B/C/H-12	6.5 ~ 7.5	4.0 - 5.0

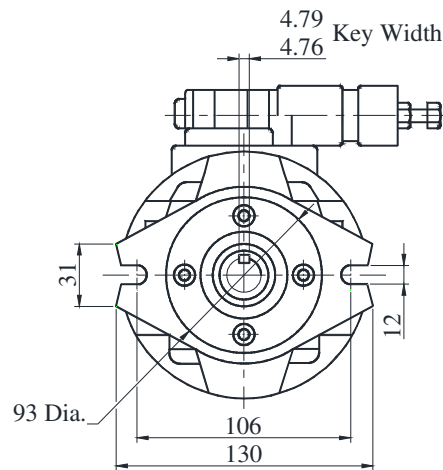

View Arrow X

A10-FR01B-12

● **Flange Mounting**

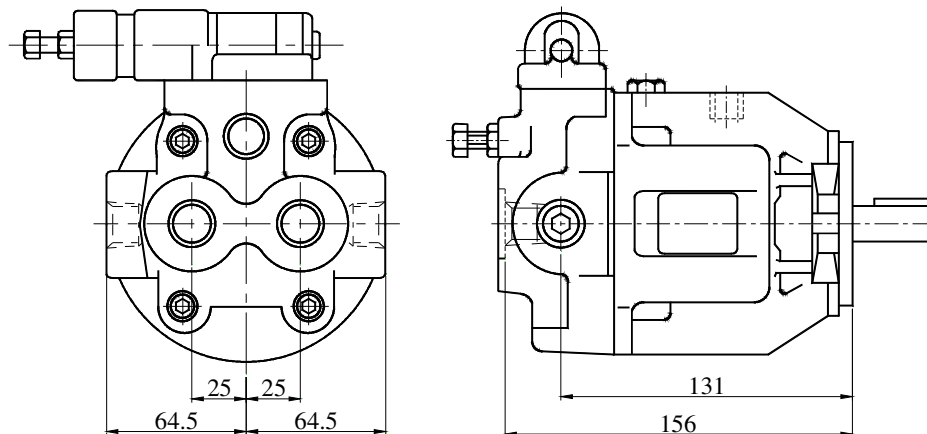

* For other dimensions, refer to above drawing.

**“A” Series Variable Displacement Piston Pumps
Single pump, Pressure Compensator Type**

- **A16-F-R-01-※-K-32**
- **A22-F-R-01-※-K-32**

Axial Port Type

● **Flange Mounting**

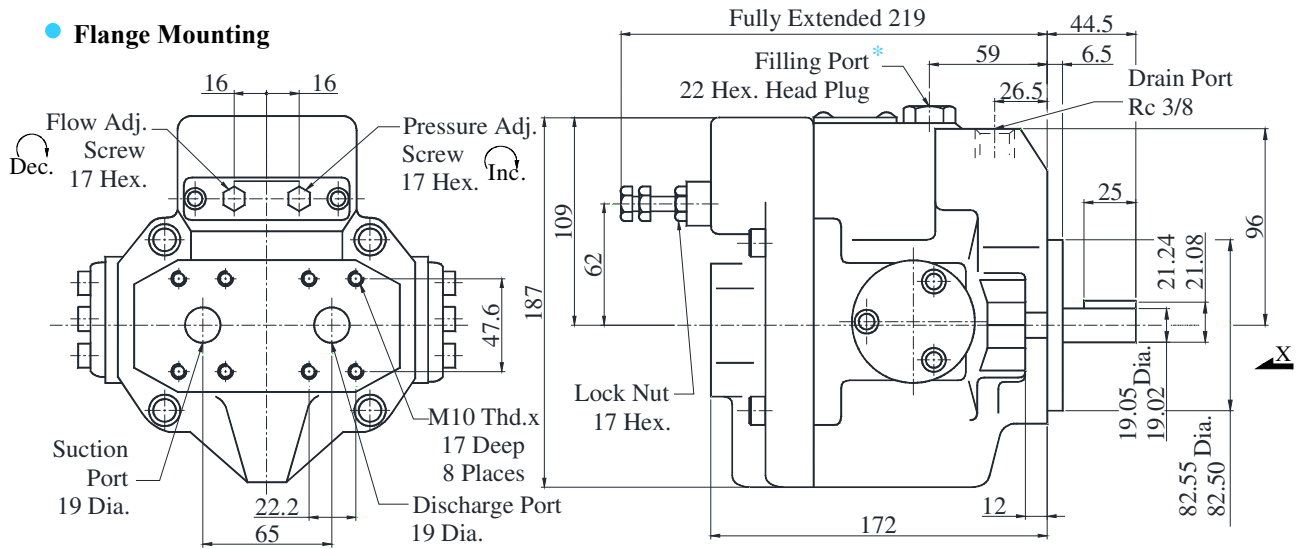

* Install the pump so that the "Filling Port" is at the top.

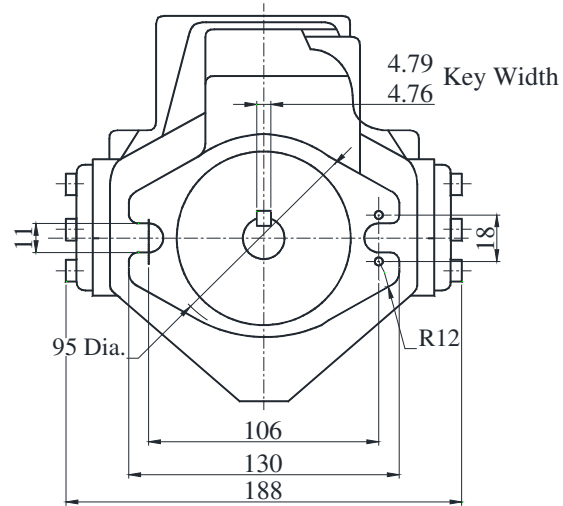

View Arrow X

- **A16-F-R-01-※-S-K-32**
- **A22-F-R-01-※-S-K-32**

● **Flange Mounting**

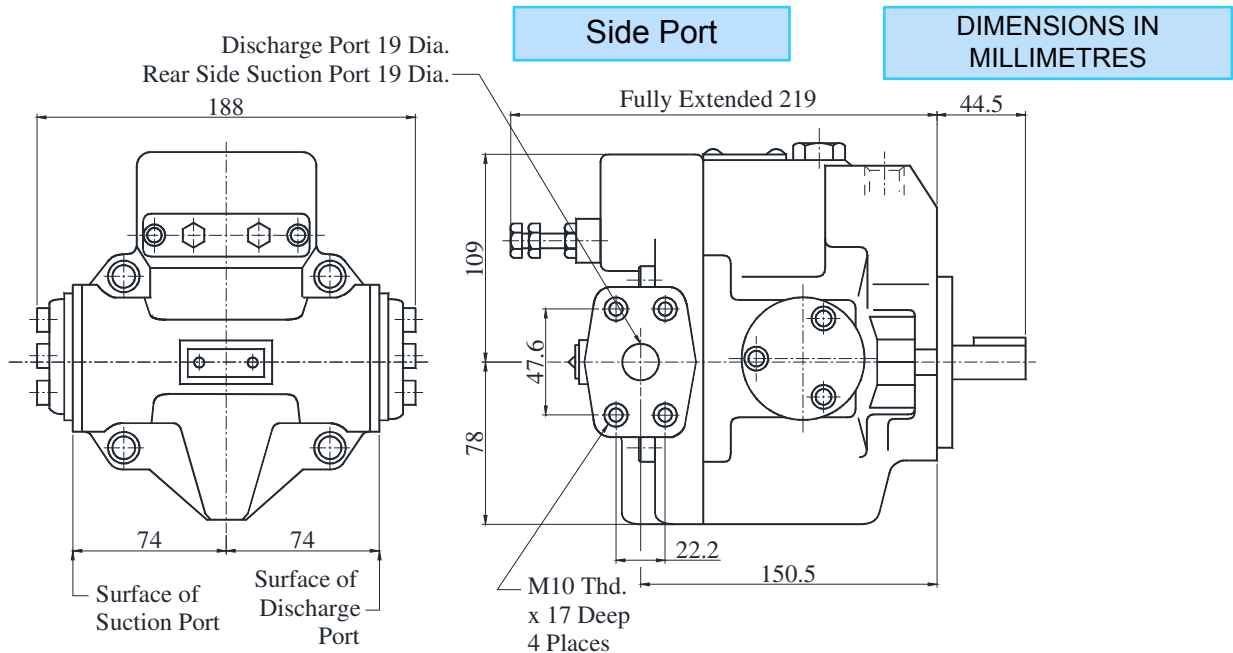

Side Port

DIMENSIONS IN MILLIMETRES

● **Foot Mounting type**

Note : For Foot Mounting Type refer page no. 29.

A37-F-R-01-※-K-32

Axial Port Type

● **Flange Mounting**

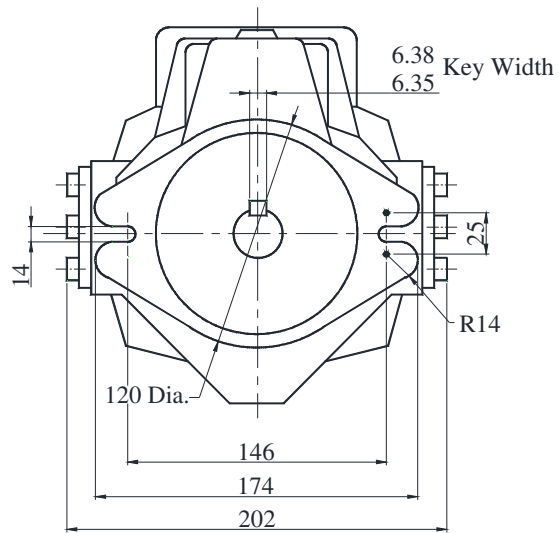
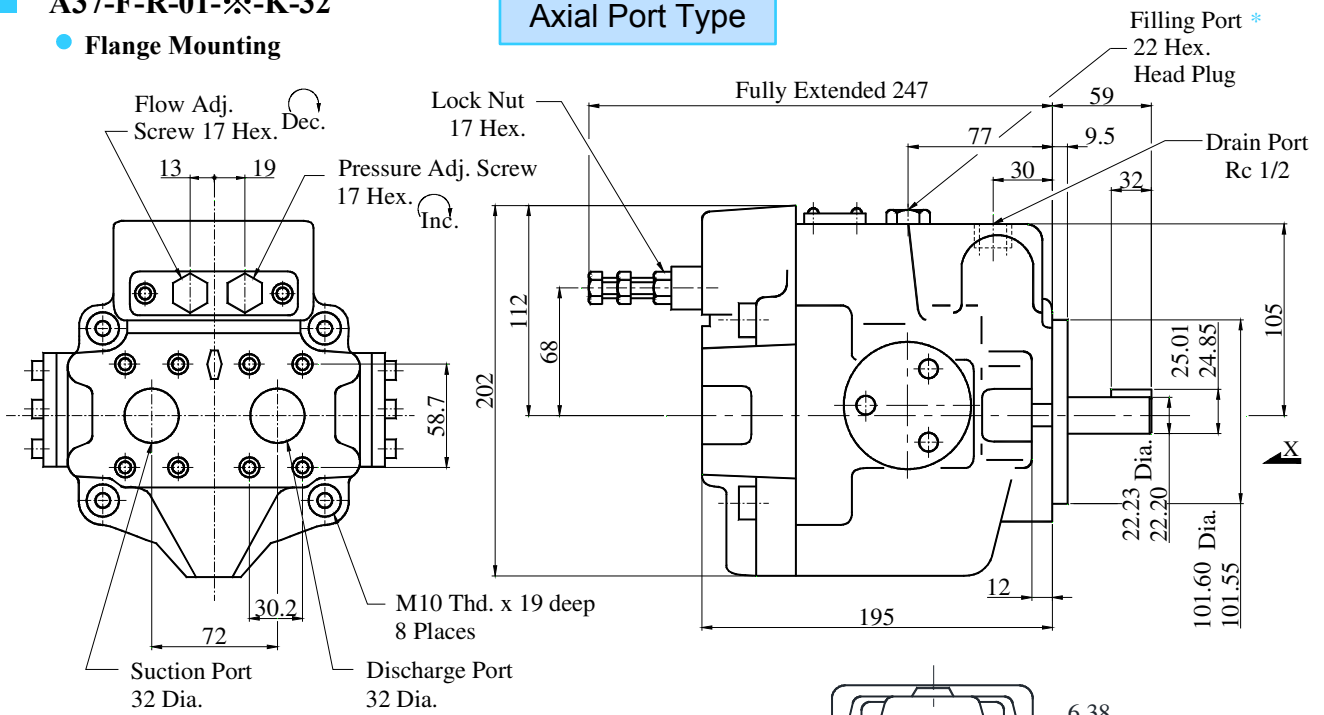

View Arrow X

DIMENSIONS IN MILLIMETRES

*Install the pump so that the “ Filling Port” is at the top.

A37-F-R-01-※-S-K-32

Side Port

● **Flange Mounting**

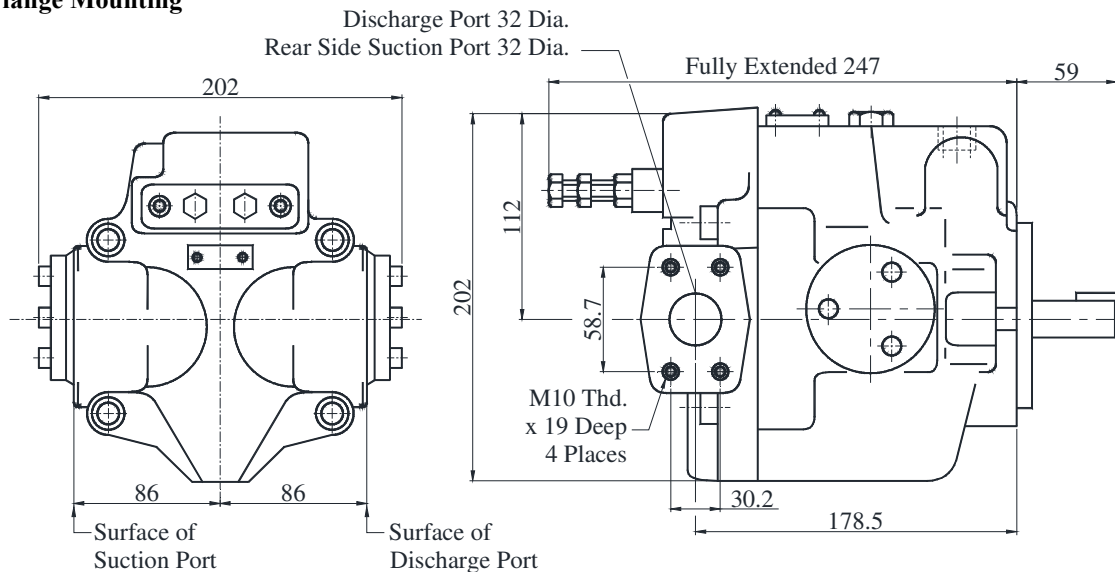

● **Foot Mounting type**

Note : For Foot Mounting Type refer page no. 30.

**“A” Series Variable Displacement Piston Pumps
Single pump, Pressure Compensator Type**

A56-F-R-01-※-K-32

Axial Port Type

Flange Mounting

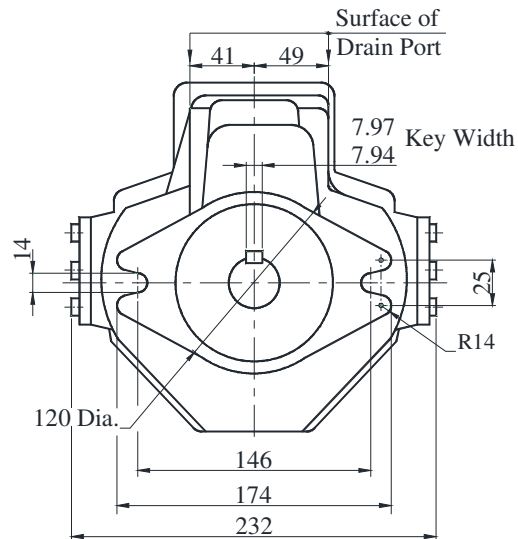
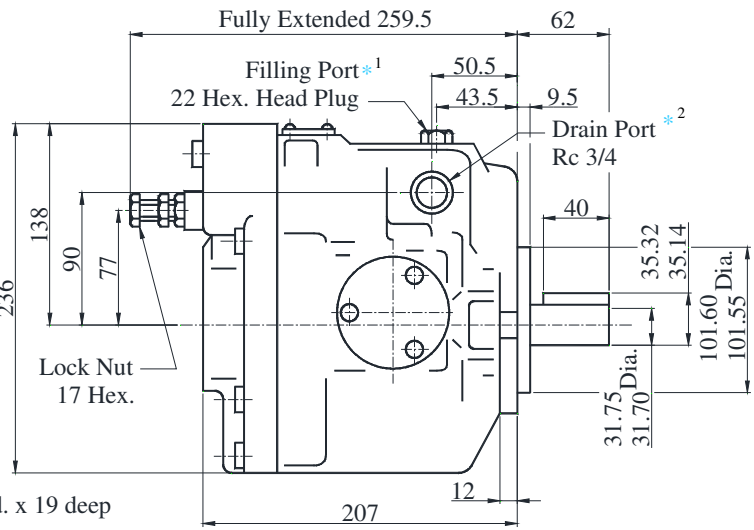
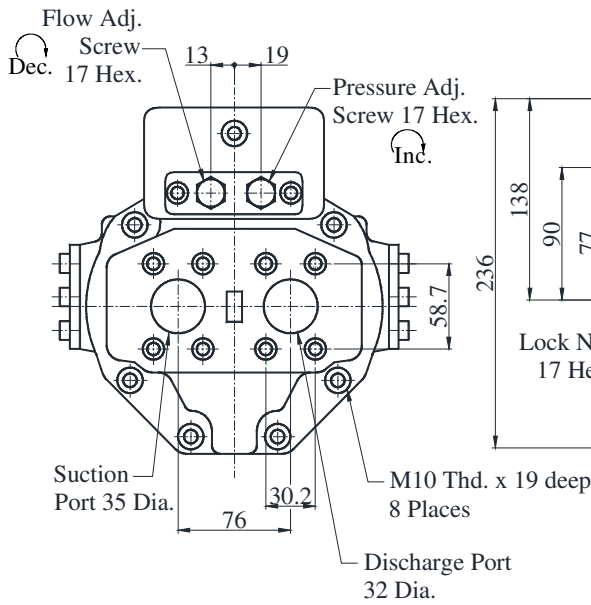

DIMENSIONS IN MILLIMETRES

- * 1 Install the pump so that the “Filling Port” is at the top.
- * 2 Use either port of two drain ports at your options. Keep the remaining ports plugged. Note that the drain port is machined only on the left side, as viewed from the shaft end.

A56-F-R-01-※-K-32

Flange Mounting

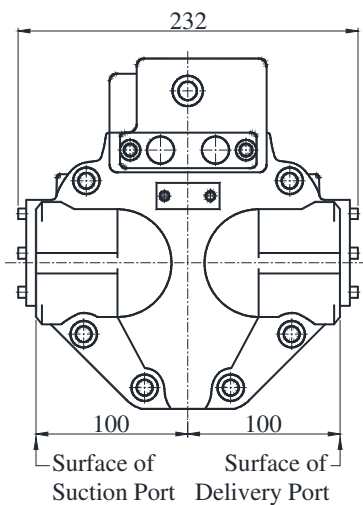

Side Port

Discharge Port 32 Dia.
Rear Suction Port 35 Dia.

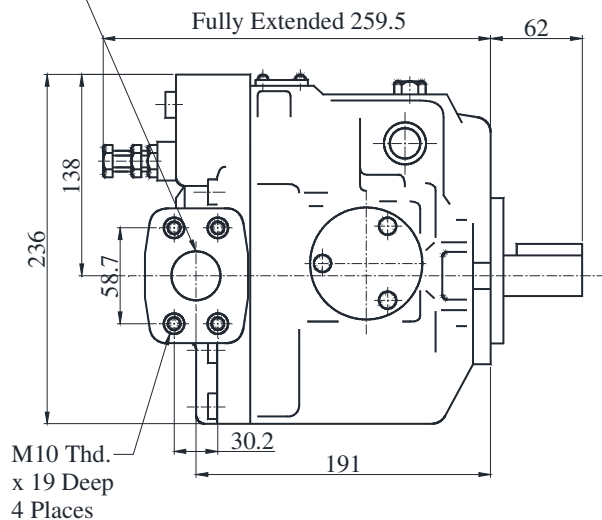

Foot Mounting type

Note : For Foot Mounting Type refer page no. 31.

A70-FR01※-S-60

Side Port Type

DIMENSIONS IN MILLIMETRES

● **Flange Mounting**

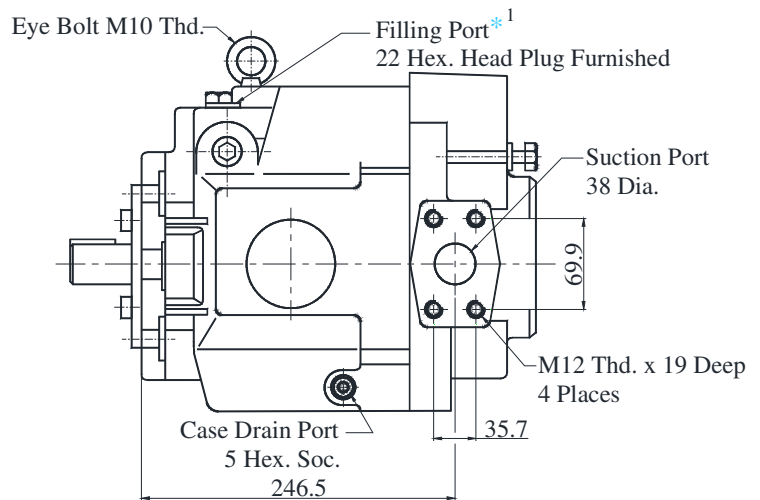
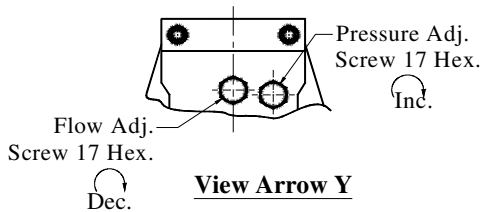
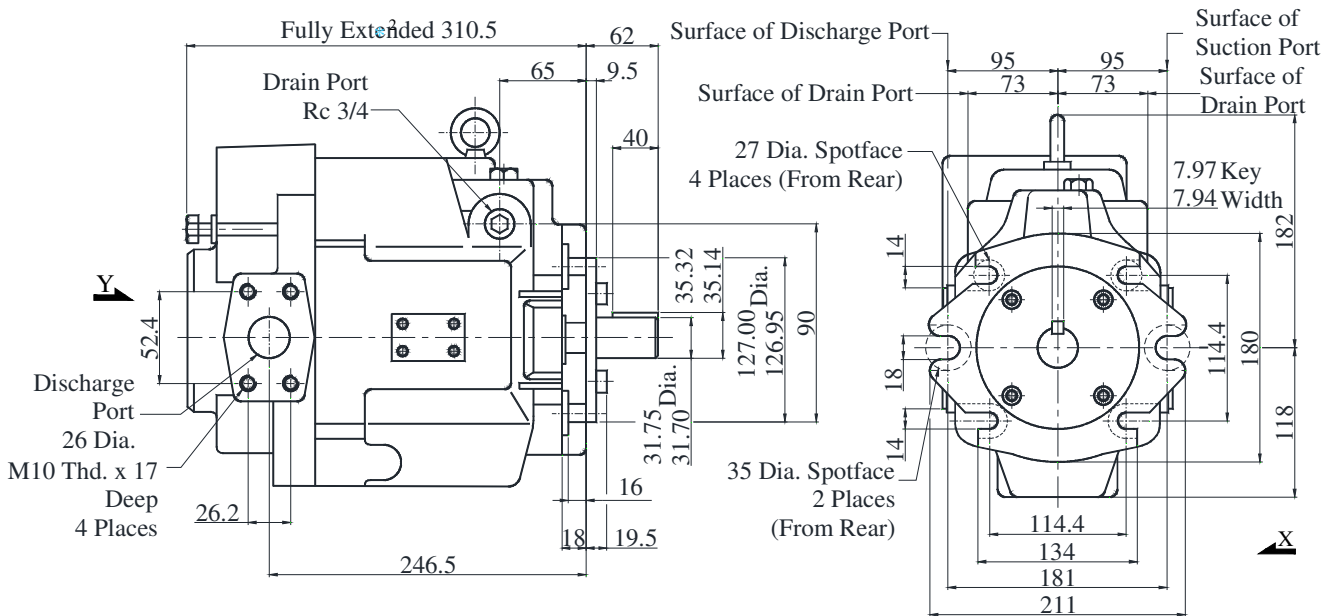

- * 1 Install the pump so that the “Filling Port” is at the top.
- * 2 Use either port of two drain ports at your options. Keep the remaining ports plugged.
Note that the drain port is machined only on the left side, as viewed from the shaft end.
- * 3 Case drain ports are available for use when draining hydraulic fluid from pump casing.

● **Foot Mounting type**

Note : For Foot Mounting Type refer page no. 32.

A90-FR01※-S-60

Side Port Type

● **Flange Mounting**

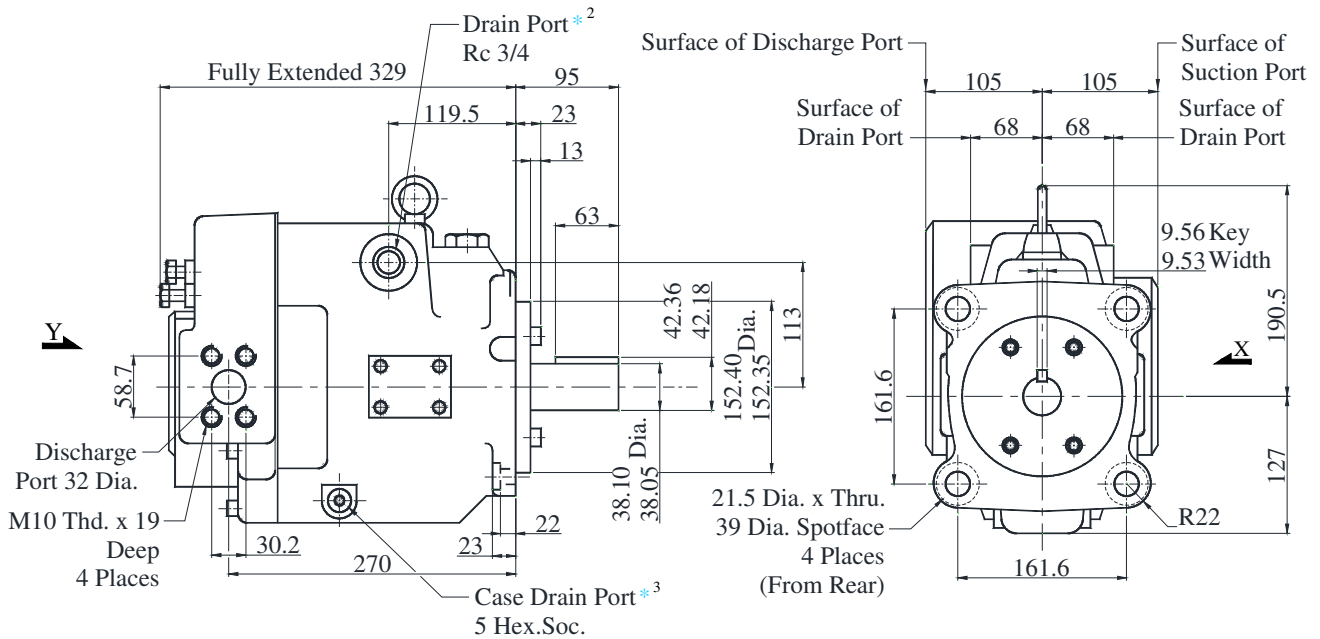

DIMENSIONS IN MILLIMETRES

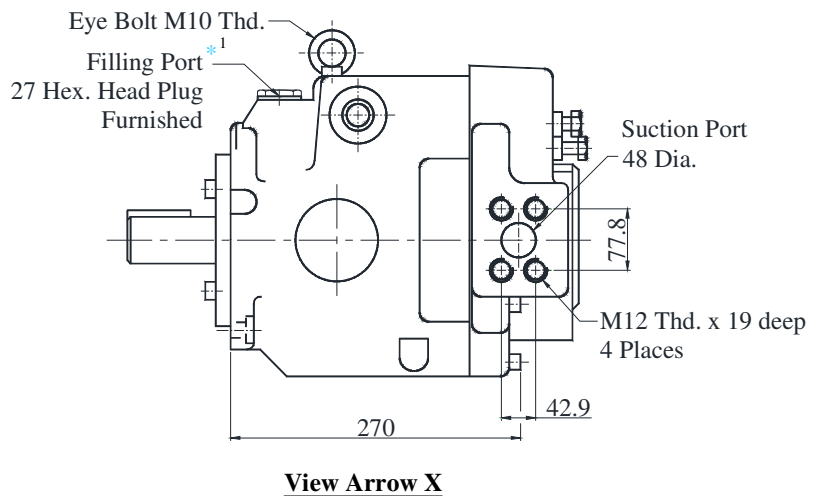
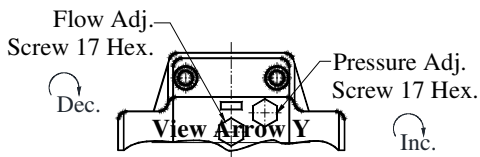

- * 1 Install the pump so that the “Filling Port” is at the top.
- * 2 Use either port of two drain ports at your options. Keep the remaining ports plugged. Note that the drain port is machined only on the left side, as viewed from the shaft end.
- * 3 Case drain ports are available for use when draining hydraulic fluid from pump casing.

● **Foot Mounting type**

Note : For Foot Mounting Type refer page no. 33.

A145-FR01※-S-60

Side Port Type

DIMENSIONS IN MILLIMETRES

● **Flange Mounting**

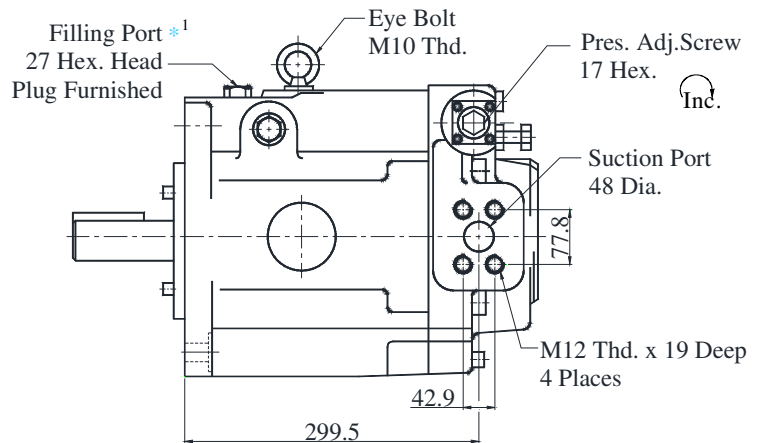
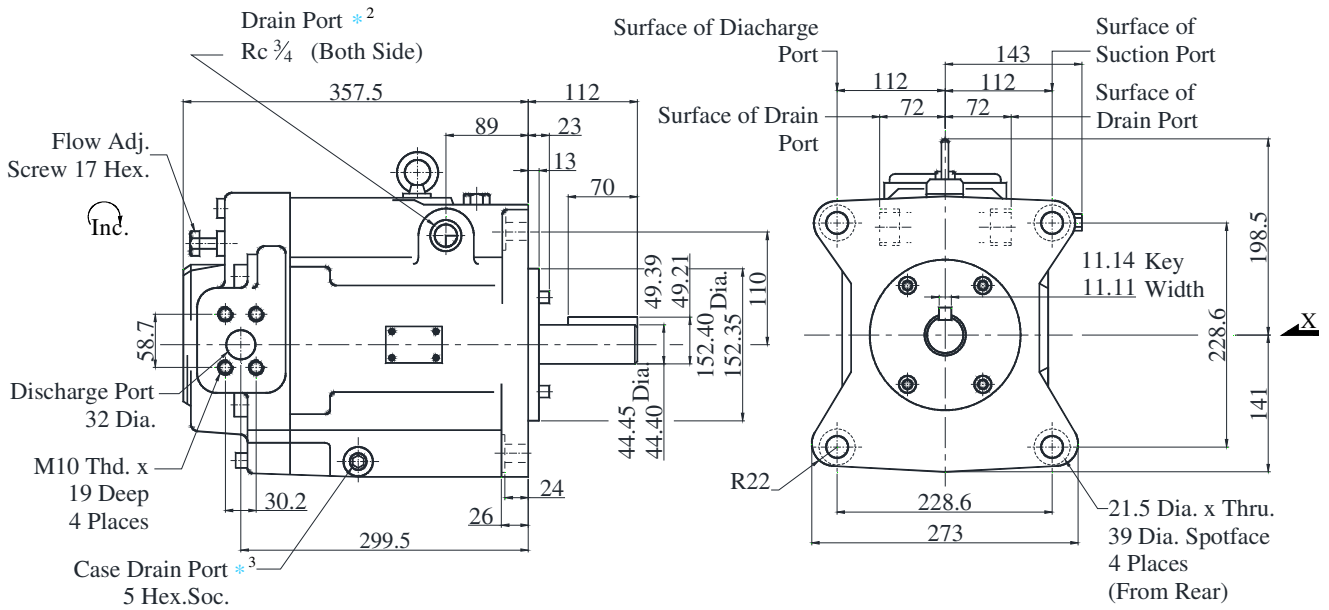

View Arrow X

- * 1 Install the pump so that the “Filling Port” is at the top.
- * 2 Use either port of two drain ports at your option. Keep the remaining ports plugged. Note that the drain port is machined only on the left side, as viewed from the shaft end.
- * 3 Case drain ports are available for use when draining hydraulic fluid from pump casing.

● **Foot Mounting type**

Note : For Foot Mounting Type refer page no. 34.

■ A70/90-※R01※S-60

● **List of Seals**

Sl. No.	Name of Parts	Parts Numbers		Qty.
		A70-※R01※S	A90-※R01※S	
1	Gasket	1314E-PK2 11972-5	1310E-PK2 11973-3	1
2	Back up Ring	1310E-PK4 12440-0		1
3	Oil Seal	TCN 355511	TCN 456812	1
4	O-Ring	SO-FA-G85	SO-FA-G95	1
5	O-Ring	SO-NA-P18		1
6	O-Ring	SO-NB-P9		3
7	O-Ring	SO-NB-P14	SO-NB-P18	1
8	Seal Washer	W10	-	1
9	O-Ring	SO-NB-P5		1

● **List of Seals Kits**

Pump Model Numbers	Seal Kit Numbers
A70-※R01※S-60	KS-A70-01-60
A90-※R01※S-60	KS-A90-01-60

Note: When ordering the seals, please specify the seal kit number from the table above.

■ A145-※R01※S-60

● **List of Seals**

Sl. No.	Name of Parts	Parts Number	Qty.
1	O-Ring	S-31.5(NBR, Hs70)	1
2	O-Ring	SO-FA-G105	1
3	O-Ring	SO-NA-P18	1
4	O-Ring	SO-NB-P9	2
5	O-Ring	SO-NB-A017	1
6	O-Ring	SO-NB-A016	1
7	O-Ring	SO-NB-P18	1
8	O-Ring	SO-NB-P5	1
9	Back Up Ring	1301E-PK4 12440-0	1
10	Back Up Ring	For SO-NB-A017	1
11	Back Up Ring	For SO-NB-A016	1
12	Oil Seal	TCN 507212	1
13	Gasket	1321-PK2 11974-1	1

Note: When ordering seals, please specify the seal kit number KS-A145-01-60.

**“A” Series Variable Displacement Piston Pumps-Single Pump,
Proportional Electro-Hydraulic Load Sensing Type**

A

“A” Series Variable
Displacement Piston Pumps

Performance Characteristic

Graphic Symbol

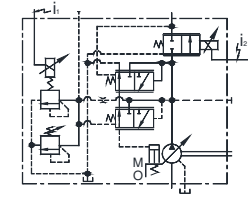
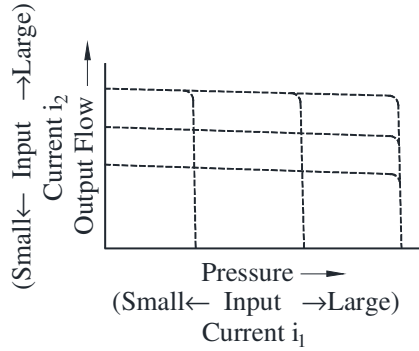
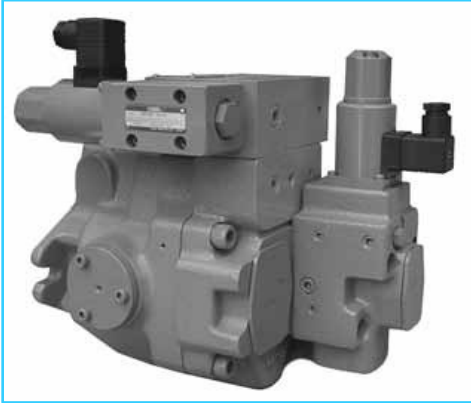

A16/A22/A37/A56

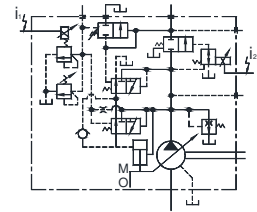

A70/A90/A145

Model Number Designation

A56	-F	-R	-04	-C	-K	-32
Series Number	Mounting	Direction of Rotation	Control Type	Pressure Adj. Range Kgf/cm ²	Shaft Extension	Design Number*
A16 (15.8 cm ³ /rev.)	F: Flange Mtg.	(Viewed from Shaft End)	04: Proportional Electro-Hydraulic Load Sensing Type	B: 15-69 C: 15-157 H: 15-206	K: Keyed Shaft	32
A22 (22.2 cm ³ /rev.)				B: 15-69 C: 15-157		32
A37 (36.9 cm ³ /rev.)	L: Foot Mtg.	R: Clockwise* ¹		B: 20-69 C: 20-157 H: 20-206		32
A56 (56.2 cm ³ /rev.)				32		

A70	-F	R	04	C	S	-60
Series Number	Mounting	Direction of Rotation	Control Type	Pressure Adj. Range Kgf/cm ²	Shaft Extension	Design Number*
A70 (70.0 cm ³ /rev.)	F: Flange Mtg.	(Viewed from Shaft End)	04: Proportional Electro-Hydraulic Load Sensing Type	C: 15-160 H: 15-210	S: Side Port	60
A90 (91.0 cm ³ /rev.)						60
A145 (145 cm ³ /rev.)	L: Foot Mtg.	R: Clockwise* ¹				60

*1 Available to supply pump with anti-clockwise rotation. Consult Yuken for details.

■ Pipe Flange Kits

Pipe Flange kits are available.
When ordering, specify the kit number from the table below.

Pump Model Numbers	Name of Port	Pipe Flange Kit Numbers.	
		Threaded Connection	Socket Welding ¹
A16-※-R-04	Suction	F5-06-A-1080	F5-06-B-10
A22-※-R-04	Discharge	—*2	—*2
A37-※-R-04	Suction	F5-10-A-1080	F5-10-B-10
A56-※-R-04	Discharge	F5-06-A-1080	F5-06-B-10
A70-※ R04	Suction	F5-12-A-1080	F5-12-B-10
	Discharge	F5-10-A-1080	F5-10-B-10
A90-※ R04	Suction	F5-16-A-1080	F5-16-B-10
A145-※ R04	Discharge	F5-10-A-1080	F5-10-B-10

- *1 In case of using socket welding flanges, there is a case where the operating pressure should be set lower than the normal because of strength of the flanges. Therefore, please pay cautious attention to the operating pressure when the socket welding flanges are used.
- *2 Discharge port for pump model “A16” and “A22” is available only the threaded connections.
- Details of pipe flange kits are described in EIC-L-1001.

■ Instructions

- **Bleeding Air**
In order to get steadily controlled pressure and flow, bleed air by loosening the air vent screw and fill solenoid armature with operating oil.
- **Manual Adjustment Screws**
Manual adjustment screws may be used for initial running adjustment or in case of electrical failures in order to adjust pressure and flow temporarily. In case of normal use, put the manual adjustment screws back in their preset position.
- **Position of Cable Departure**
Position of cable departure can be changed. For details, refer to EDG-01 valve in EIC-H-1001.
- **Connection of Surge Cut-off Valve to “A” Series Pump (For A16 to A56 Type)**
If using surge cut-off valve (SF1105-A-10), connect between pilot port “PP” of this pump and port “PP” of surge cut-off valve as pilot piping (refer to drawing below).
Inside diameter of pipe should be more than 8 mm.
Consult Yuken for details of surge cut-off valve.

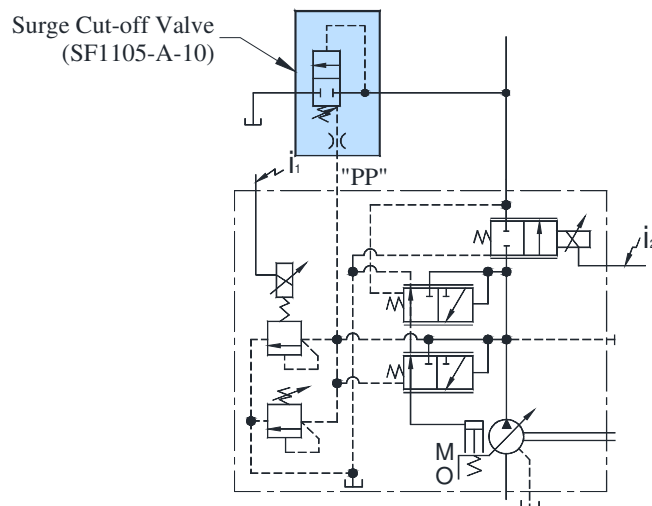

**“A” Series Variable Displacement Piston Pumps
Single Pump, Proportional Electro-Hydraulic Load Sensing Type**

Specifications

Model Number		A16	A22	A37	A56	A70	A90	A145	
Descriptions									
Geometric Displacement cm ³ /rev.		15.8	22.2	36.9	56.2	70.0	91.0	145	
Operating Pres. (Kgf/cm ²)	Rated ^{*2}	160	160	160	160	210	210	210	
	Intermittent ^{*1}	210	160	210	210	210	210	210	
Shaft Speed Range r/min.	Max.	1800	1800	1800	1800	1800	1800	1800	
	Min.	600	600	600	600	600	600	600	
Flow Control	Flow Adj. Range L/min.	1-28.4	1-40	1-66	1-101	1-126	1-163	2-261	
	Min. Pres. Required for Flow Adj. Kgf/cm ²	15	15	15	20	10	10	10	
	Differential Pres. Kgf/cm ²	3.7				2.2			
	Step Response ^{*5} (0→Max. Flow) ms	70	80	120	125	100	120	210	
	Hysteresis	3% or less ^{*4}							
	Rated Current mA	900	700	740	790	820	920	920	
	Coil Resistance [20°C]	10							
Pressure Control	Pres. Adj. Range Kgf/cm ²	Refer to model Number Designation							
	Step Response ms	t ₁ ^{*5}	80	80	50	55	150	150	160
		t ₂ ^{*5}	140	90	80	80	80	120	180
	Hysteresis	2% or less ^{*4}							
	Rated Current mA	(Pres. Adj. Range) B: 770, C:880, H:790					C: 860 H: 765	C: 873 H: 765	C: 875 H: 755
Coil Resistance [20°C]	10								
Applicable Amplifier Model ^{*3}		AME-D2-1010-11							
Approx. Mass Kg.	Flange Mtg.	32	32	38	45	72.5	88.5	109.5	
	Foot Mtg.	34.2	34.2	43.2	49.3	84.5	109	134.5	

Model	Pres. Step Response		Loading Volume
	t ₁	t ₂	
A16, A22	15 → 160 Kgf/cm ²	160 → 15 Kgf/cm ²	High Pressure Hose 3/8" x 2 m
A37, A56	20 → 160 Kgf/cm ²	160 → 20 Kgf/cm ²	High Pressure Hose 3/4" x 2 m
A70, A90, A145	30 → 160 Kgf/cm ²	160 → 30 Kgf/cm ²	High Pressure Hose 1-1/4" x 2 m

- *1 Whenever setting pressure, make sure the full cut-off pressure never exceeds the maximum intermittent pressure.
- *2 When operating the pump exceeding the rated pressure, operating conditions are restricted. Refer to page no. 6 .
- *3 For detail specifications of power amplifiers, refer to EIC-H-1008.
- *4 The figure mentioned in the above table are those obtained using Yuken’s amplifier.
- *5 Step response depends on circuit and operating conditions. Data shown in the table above is an example based on the condition right.

**“A” Series Variable Displacement Piston Pumps
Single Pump, Proportional Electro-Hydraulic Load Sensing Type**

Full Cut-off Pres. Vs. Input Current

● **A16/A22/A37/A56**

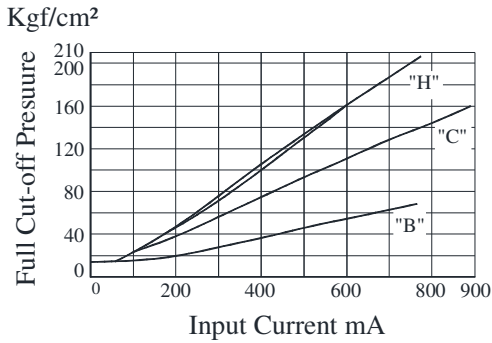

Note : Pressure adjustment range "H" is not available for A22.

● **A70/A90/A145**

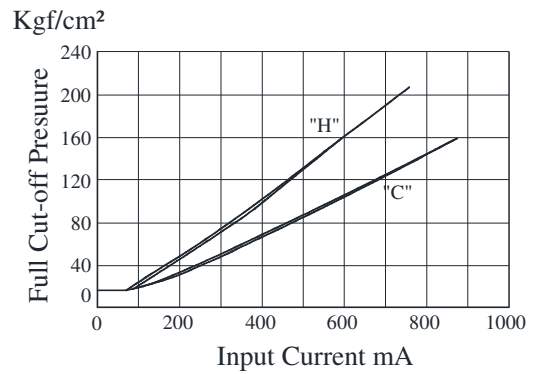

Output Flow vs. Input Current

● **A16**

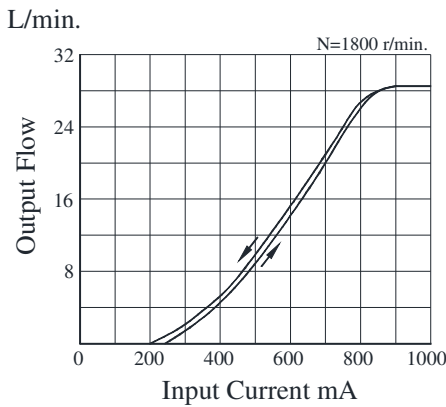

● **A22**

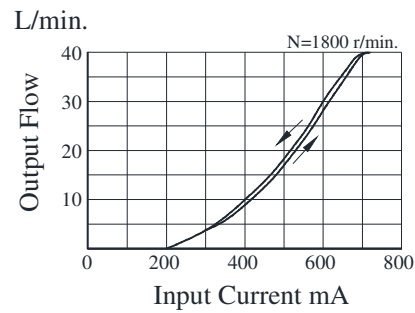

● **A37**

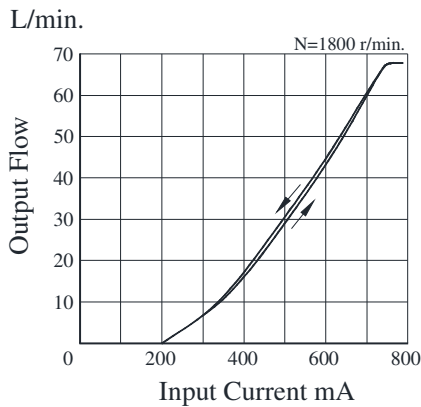

● **A56**

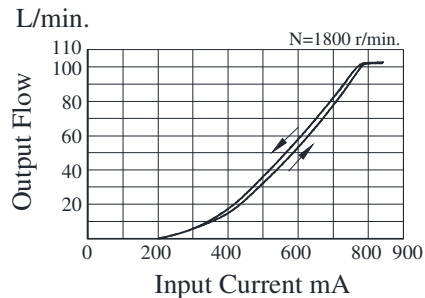

● **A70**

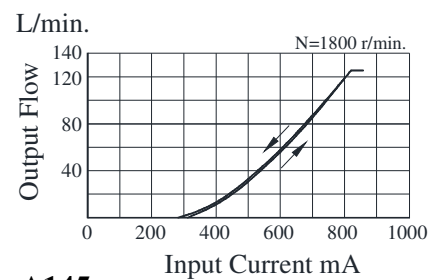

● **A90**

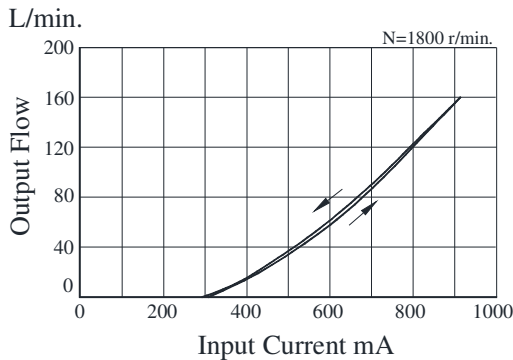

● **A145**

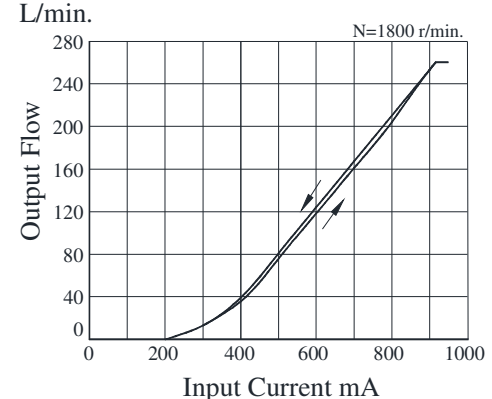

"A" Series Variable Displacement Piston Pumps

Single Pump, Proportional Electro-Hydraulic Load Sensing Type

A16-F-R-04-※-K-32
A22-F-R-04-※-K-32

DIMENSIONS IN MILLIMETRES

● **Flange Mounting**

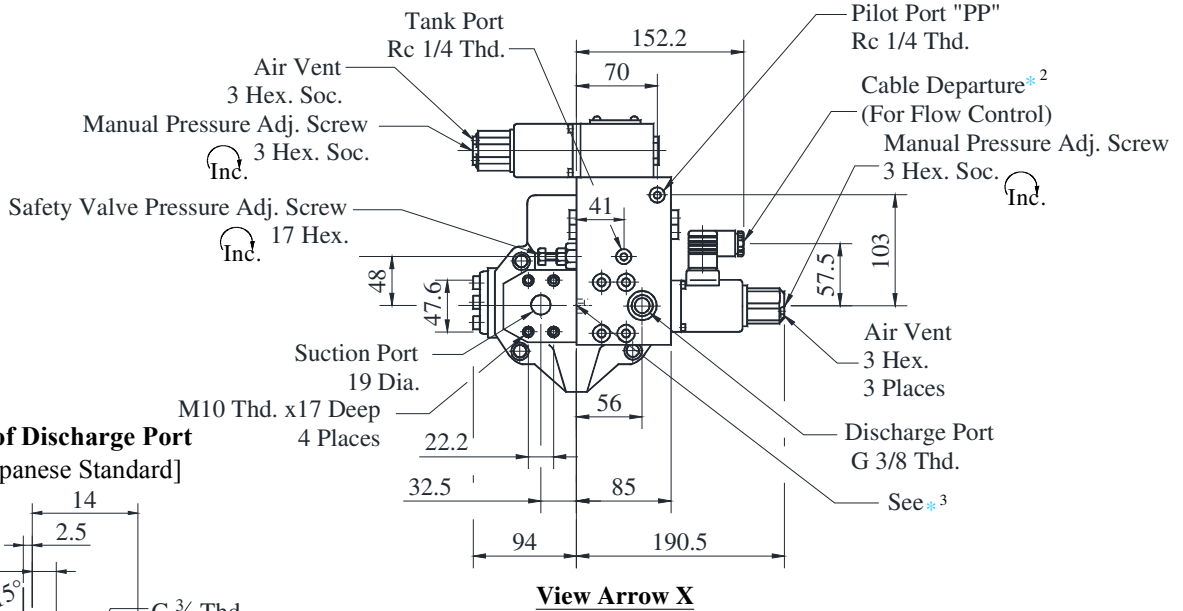
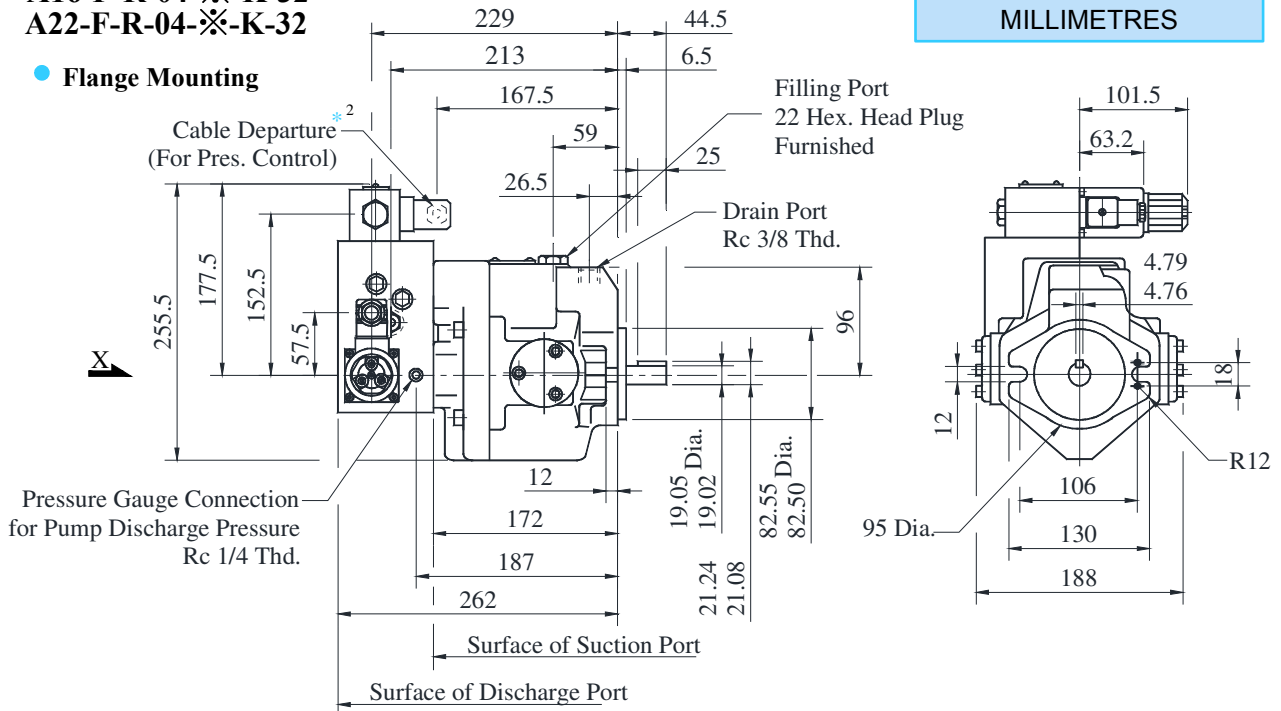

* 1 **Detail of Discharge Port**
 [For Japanese Standard]

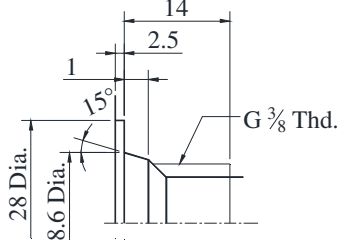

- * 2 Cable Applicable:
 Outside Dia. 8-10 mm.
 Conductor Area Not Exceeding 1.5 mm².
- * 3 Do not touch the screw because it is adjusted at the time of shipment.

● **Foot Mounting type**

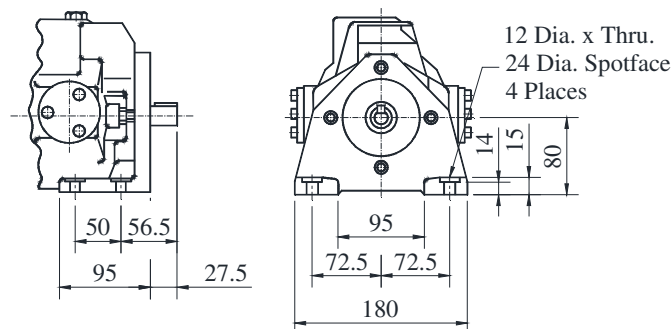

Note: For other dimensions, refer to "Flange Mtg."

"A" Series Variable Displacement Piston Pumps
Single Pump, Proportional Electro-Hydraulic Load Sensing Type

A

"A" Series Variable
 Displacement Piston Pumps

A37-F-R-04-※-K-32

Flange Mounting

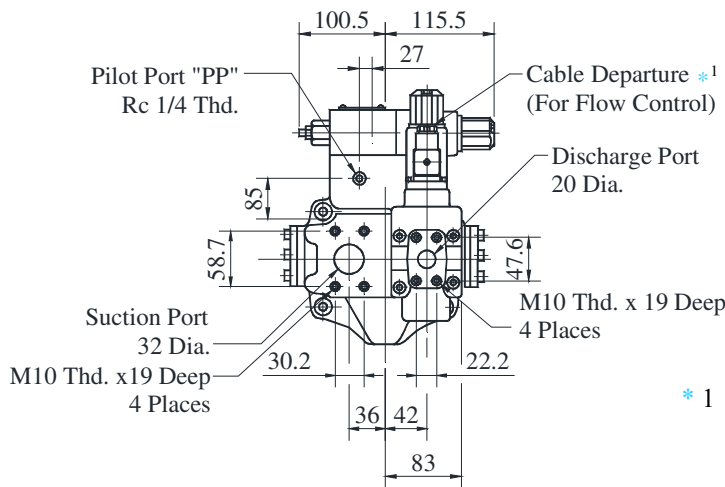
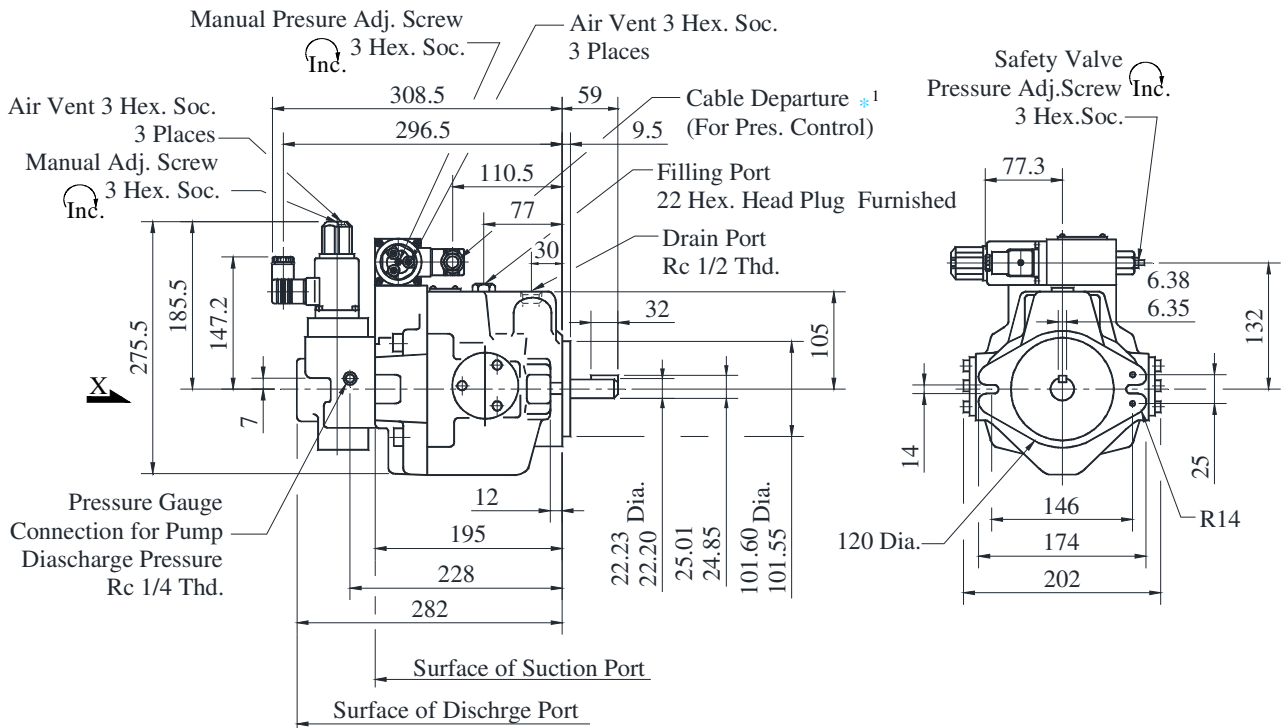

View Arrow X

* 1 Cable Applicable:
Outside Dia. 8-10 mm.
Conductor Area Not Exceeding 1.5 mm².

DIMENSIONS IN MILLIMETRES

Foot Mounting type

Mounting Bracket is common to that of pressure compensator model.

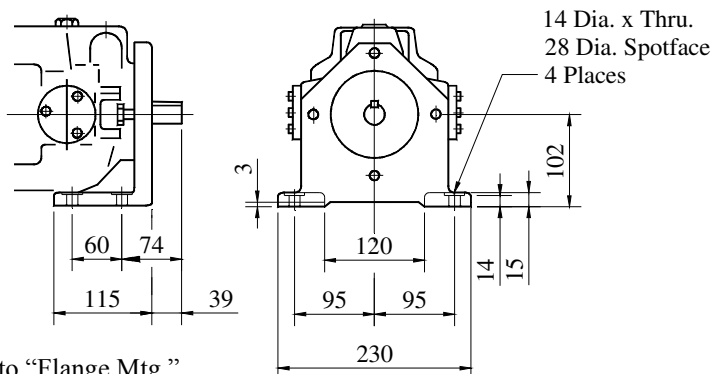

Note: For other dimensions, refer to "Flange Mtg."

"A" Series Variable Displacement Piston Pumps
Single Pump, Proportional Electro-Hydraulic Load Sensing Type

A56-F-R-04-※-K-32

● **Flange Mounting**

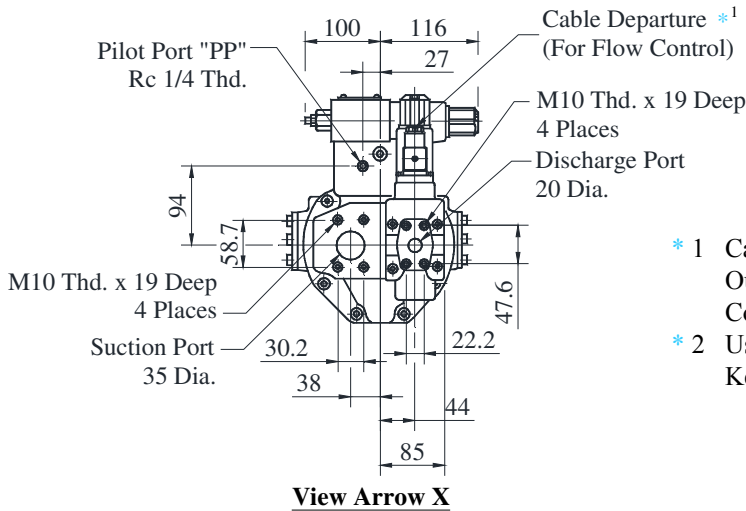
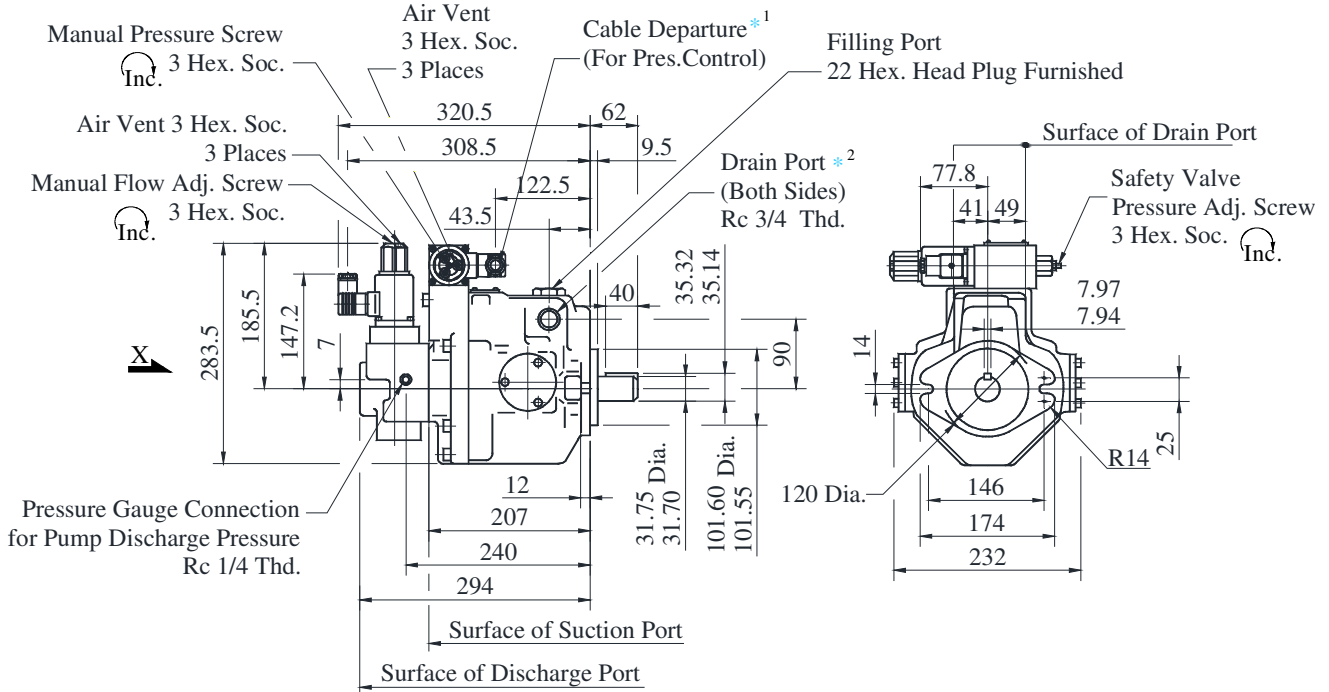

- * 1 Cable Applicable:
Outside Dia. 8-10 mm.
Conductor Area Not Exceeding 1.5 mm².
- * 2 Use either port of two drain ports at your option.
Keep the remaining port plugged.

DIMENSIONS IN MILLIMETRES

A56-L-R-04-※-K-32

● **Foot Mounting type**

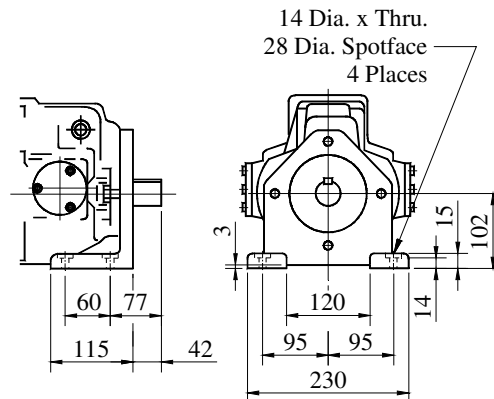

Note: For other dimensions, refer to "Flange Mtg."

A70-FR04※S-60

Flange Mounting

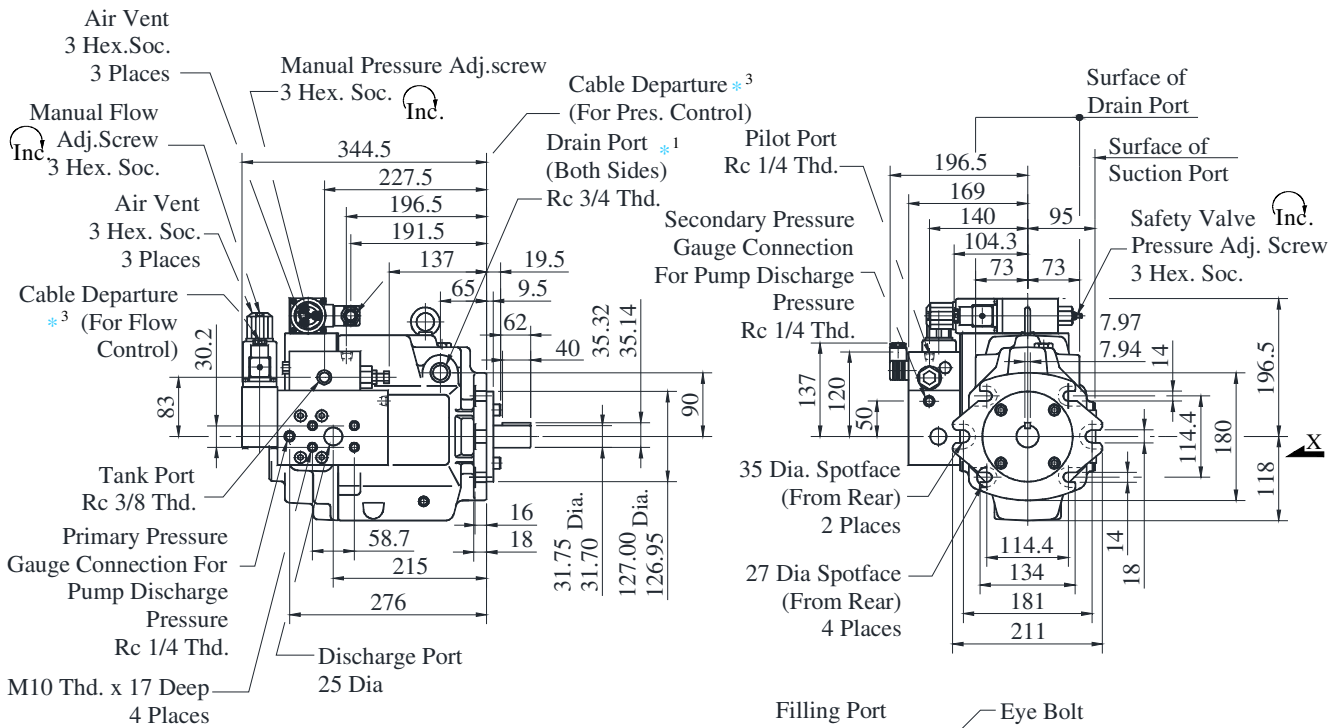

- * 1 Use either port of two drain ports at your option. Keep the remaining port plugged.
- * 2 Case drain port is available for use when draining hydraulic fluid from pump casing.
- * 3 Cable Applicable:
Outside Dia. 8-10 mm.
Conductor Area Not Exceeding 1.5 mm².

View Arrow X

DIMENSIONS IN MILLIMETRES

A70-LR04※S-60

Foot Mounting type

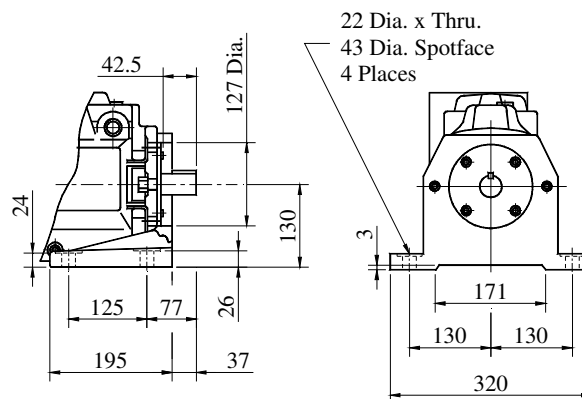

Note: For other dimensions, refer to "Flange Mtg."

"A" Series Variable Displacement Piston Pumps

Single Pump, Proportional Electro-Hydraulic Load Sensing Type

A90-FR04※S-60

Flange Mounting

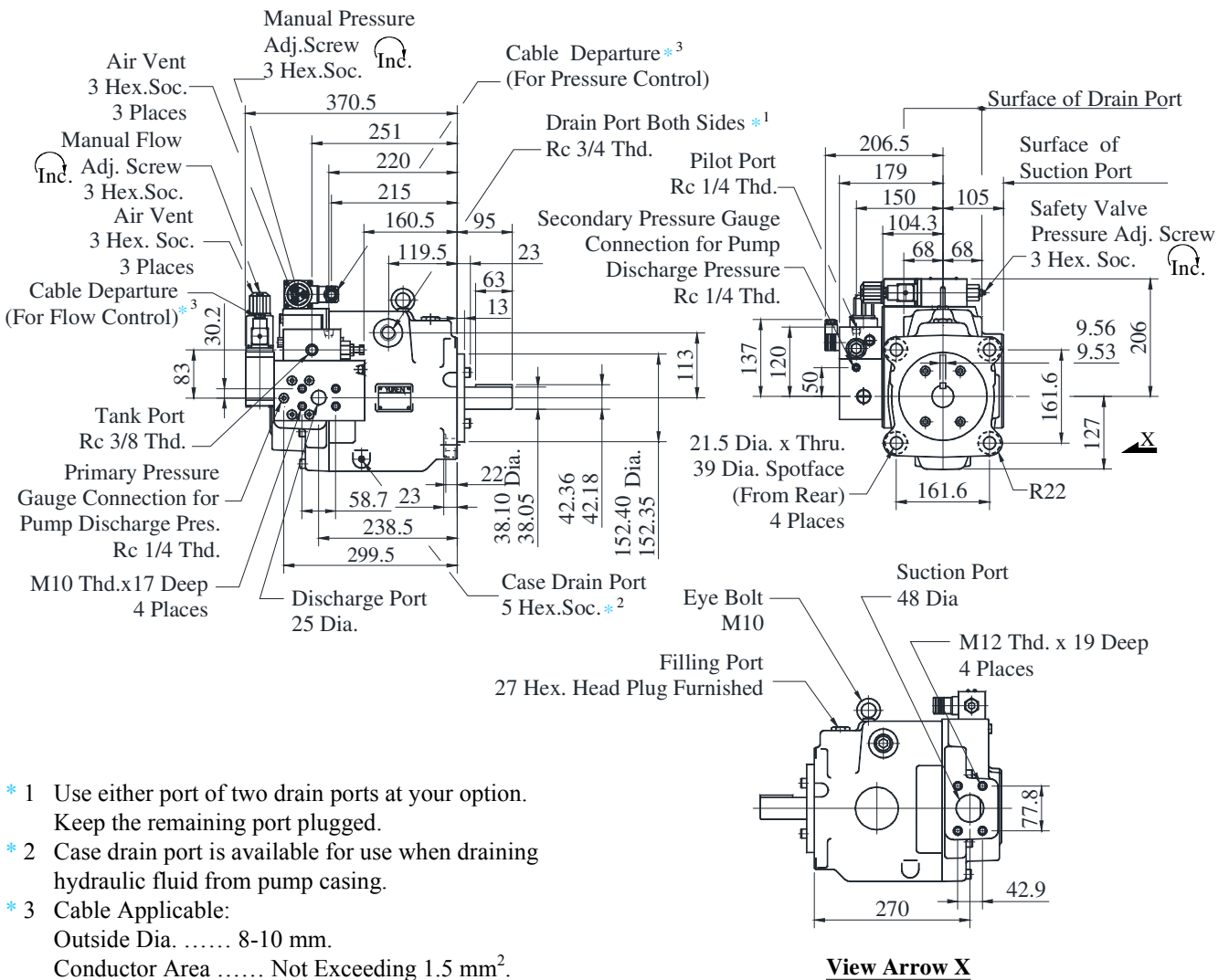

- * 1 Use either port of two drain ports at your option. Keep the remaining port plugged.
- * 2 Case drain port is available for use when draining hydraulic fluid from pump casing.
- * 3 Cable Applicable:
Outside Dia. 8-10 mm.
Conductor Area Not Exceeding 1.5 mm².

DIMENSIONS IN MILLIMETRES

A90-LR04※S-60

Foot Mounting

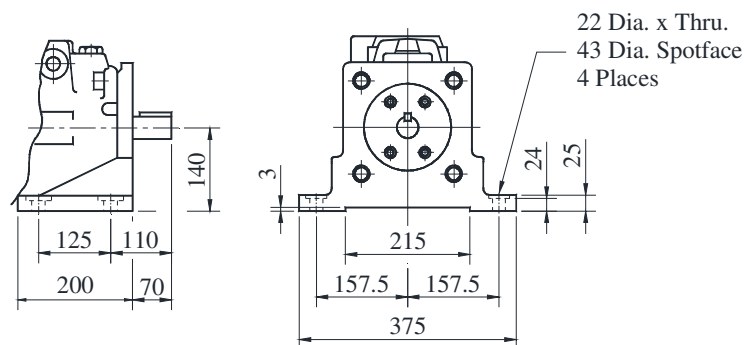

Note: For other dimensions, refer to "Flange Mtg."

A145-FR04※S-60

● **Flange Mounting**

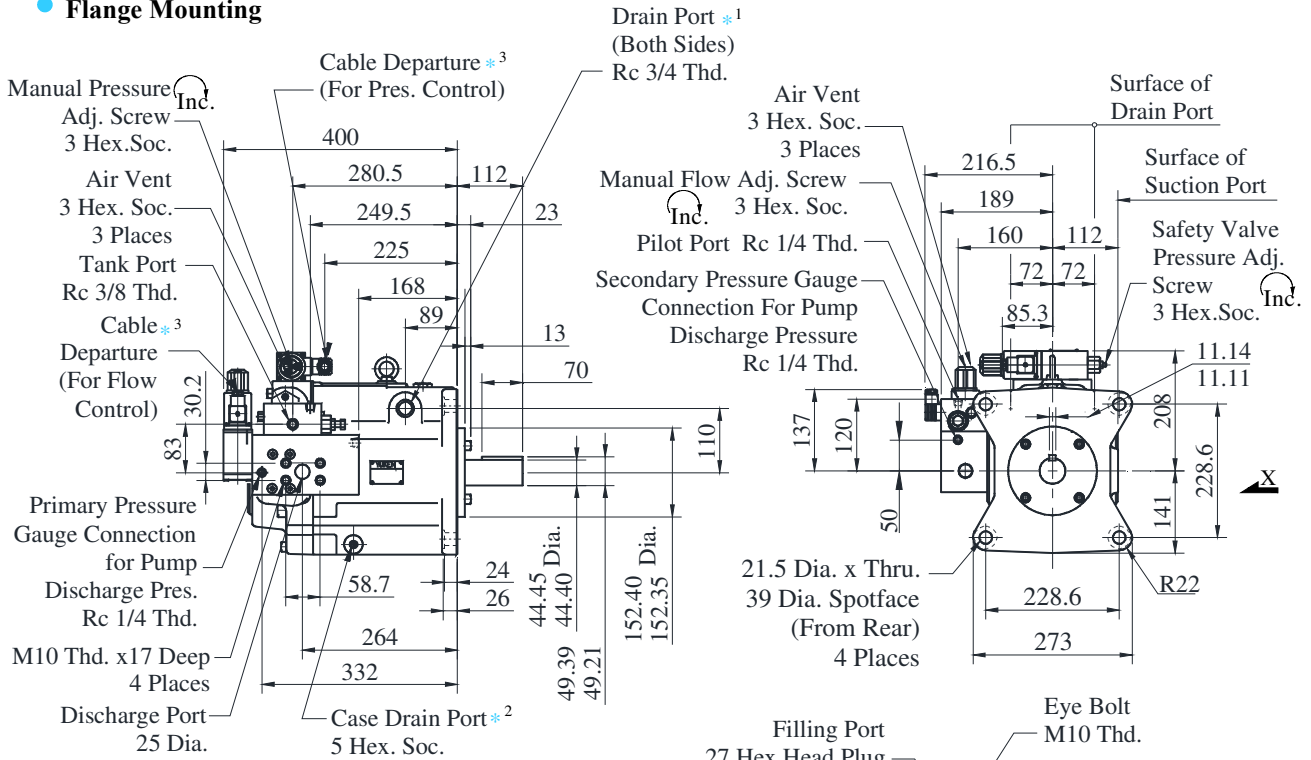

- * 1 Use either port of two drain ports at your option. Keep the remaining port plugged.
- * 2 Case drain ports are available for use when draining hydraulic fluid from pump casing.
- * 3 Cable Applicable:
Outside Dia. 8-10 mm.
Conductor Area Not Exceeding 1.5 mm².

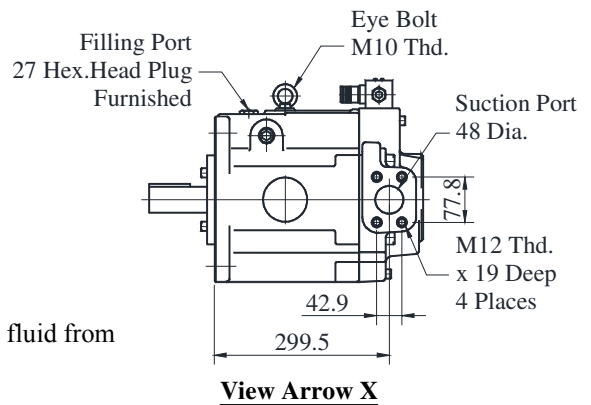

DIMENSIONS IN MILLIMETRES

A145-LR04※S-60

● **Foot Mounting type**

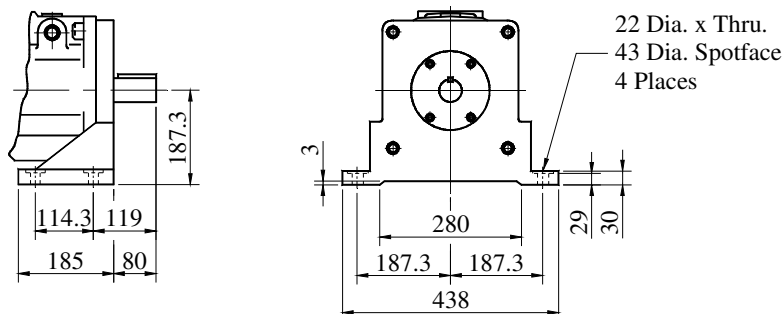

Note: For other dimensions, refer to "Flange Mtg."

"A" Series Variable Displacement Piston Pumps
Single Pump, Proportional Electro-Hydraulic Load Sensing Type

“A” Series Variable Displacement Piston Pumps - Single Pump, Electro-Hydraulic Proportional Pressure & Flow Control Type

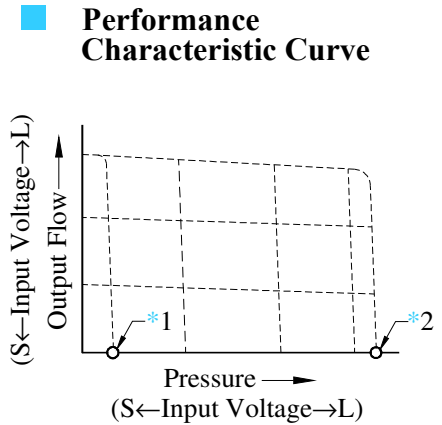
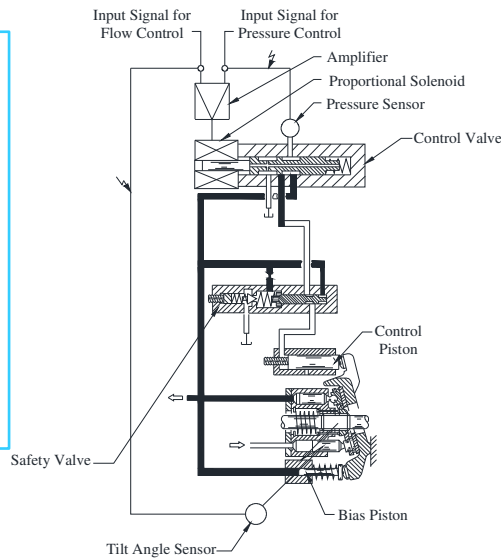

- *1 Unloading pressure when input signal is 0 V.
- *2 Safety valve setting pressure.

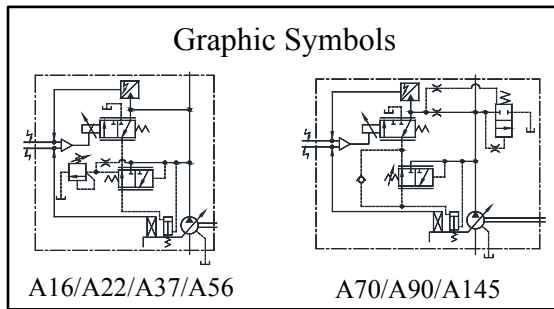

Model Number Designation

A70	-F	R	04E	16	M	A	-60	-60
Series Number	Mounting	Direction of Rotation	Control Type	Control Press. at Input Signal is 5 V	Unit of Control Pressure	Type of Outboard Pump ^{*2}	Compensation Number ^{*3}	Design Number
A16 (15.8 cm ³ /rev.)	F: Flange Mtg.	(Viewed from Shaft End)	04E: Proportional Pressure & Flow Control Type	Use the same measure of the control pressure as shown on the right, 6.9 MPa Specify within the range of maximum operating pressure	M: MPa P: PSI	None ^{*2}	06	42
A22 (22.2 cm ³ /rev.)							11	42
A37 (36.9 cm ³ /rev.)							01	42
A56 (56.2 cm ³ /rev.)							02	42
A70 (70.0 cm ³ /rev.)	L: Foot Mtg.	R: Clockwise ^{*1} (Normal)				A: ^{*2} B: ^{*2}	60	60
A90 (91.0 cm ³ /rev.)							60	60
A145 (145.0 cm ³ /rev.)							60	60

*1 Available to supply pump with anti-Clockwise rotation. Consult Yuken for details.
 *2 These pumps, except A16 and A22 types, can be connected to outboard pumps.
 - A37/A56 type (outboard pump connection symbol: **None**): spigot diameter:82.55mm (A16,A22, and PV2R1).
 - A70/A90/A145 type (outboard pump connection symbol: **“A”**): spigot diameter:82.55mm (A16,A22, and PV2R1).
 - A70/A90/A145 type (outboard pump connection symbol: **“B”**): spigot diameter:101.6mm (A37 and PV2R2).
 *3 Amplifier Compensation Number may differ according to the main machine condition. Consult Yuken for details.

Specifications

Descriptions	Model Numbers	A16	A22	A37	A56	A70	A90	A145
Geometric Displacement	cm ³ /rev.	15.8	22.2	36.9	56.2	70.0	91.0	145.0
Operating Pres. (Kgf/cm ²)	Rated ^{*2}	160	160	160	160	250	250	250
	Intermittent ^{*1}	210	160	210	210	280	280	280
Shaft Speed Range r/min.		600 - 1800						
Flow Control	Max. Flow ^{*3} L/min.	28.4	40.0	66.4	101.0	126.0	163.0	261.0
	Min. Pres. Required for Flow Adj. Kgf/cm ²	20 ^{*4}						
	Hysteresis	1% or less						
	Repeatability	1% or less						
	Input Signal	Max. Flow / 5 V DC						
Pressure Control	Min. Adj. Pressure Kgf/cm ²	7						
	Hysteresis	1% or less						
	Repeatability	1% or less						
	Input Signal	Specified Control Pressure / 5 V DC						
Coil Resistance [@ 20°C]		10						
Input Impedance		Flow Control : 10 kΩ Pres. Control : 10 kΩ						
Supply Electric Power		24 V DC (21 – 28 V Included Ripple)						
Power Input (Max.) W		30						
Output Signal	Flow	5 V DC/Max. Flow						
	Pressure	5 V DC/Specified Control Pressure						
Alarm Signal Output (Open Collector)		Voltage: Max. 30 V DC Current: Max. 40mA						
Ambient Temperature °C		0 - 50 (With Circulated Air)						
Approx. Mass Kg.	Flange Mtg.	20.5	20.5	32.0	39.0	64.0	76.5	96.4
	Foot Mtg.	22.7	22.7	36.3	43.3	76.0	97.0	121.4

- *1 Whenever setting pressure, make sure the full cut-off pressure never exceeds the maximum intermittent pressure.
- *2 When operating pump exceeding the rated pressure, operating conditions are restricted. Refer to page 6 on Catalogue No. EIC-A-1002 for the details.
- *3 Maximum flow differs to shaft speed. The value listed above indicates shaft speed of 1800 r/min. For other shaft speed calculate by the ratio of shaft speed.
- *4 To secure the required minimum pressure, special sequence valves are available, to be directly installed at the discharge port of the pump. Consult Yuken for details.

Pipe Flange Kits

For pipe flange, refer to form of pressure compensator type in page no.7 on Catalogue No. EIC-A-1002.

Instructions

Input Signal

The pump is on unload condition when the pump is operated without input signal voltage.

Electric Source

Always turn off electric source whenever the connector for swash plate tilt angle sensor is removed.

Compensation of pump Maximum Regulated Flow at Frequency

If the same maximum flow is required at 50 Hz or 60 Hz, connect short plug in the amplifier to 60 Hz at the place where supplied frequency is 60 Hz. At this condition, maximum flow comes to the same value at 50 Hz. If short plug is used at 60 Hz without making the change, maximum flow increased in proportion to frequency.

Painting on AMP. BOX and Solenoid

To Maintain suitable radiation effect, the amp. box and the solenoid of the control valve should not be painted.

Outboard Pumps

A37 to A145 type pumps, except A16 and A22, can be used as double pumps, by connecting an outboard pump on the cover side. For details consult YUKEN.

“A” Series Variable Displacement Piston Pumps Single Pump, Electro-Hydraulic Proportional Pressure & Flow Control Type

Output Flow vs. Input Signal

● **A16**

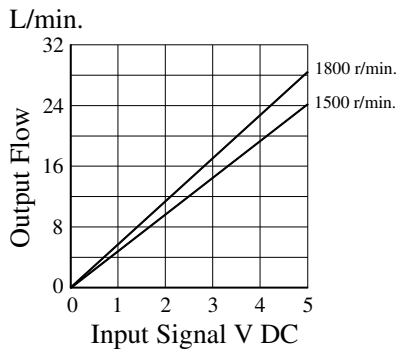

● **A56**

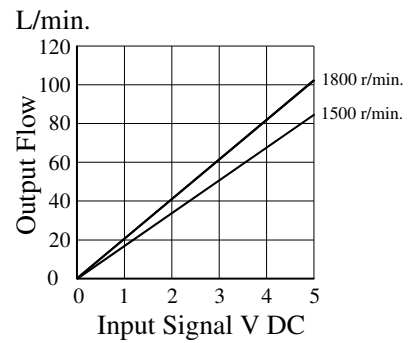

● **A22**

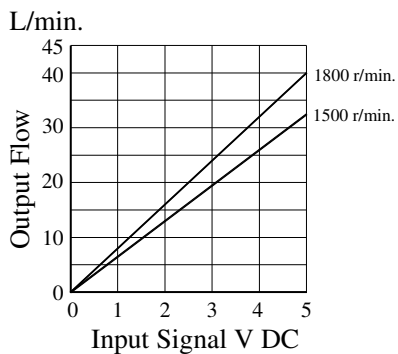

● **A70**

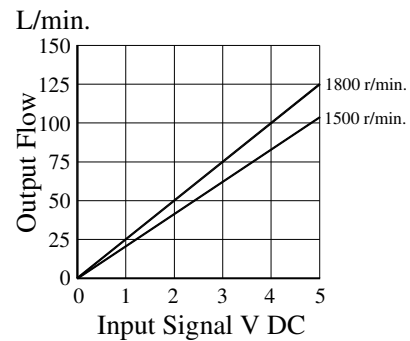

● **A37**

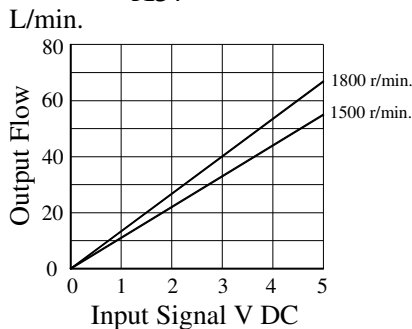

● **A90**

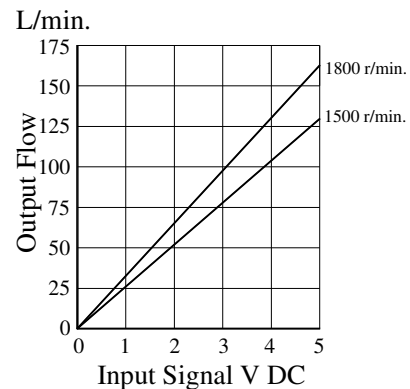

Note: Pump characteristics at 1800 r/min. is the same as those 1500 r/min. where frequency is compensated.
[Refer to page 32 of catalogue EIC-A-1002]

● **A145**

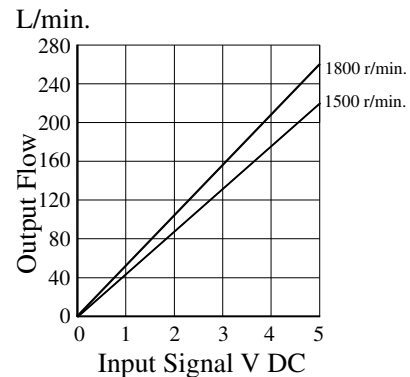

Full Cut-off Pre. Vs. Input Signal

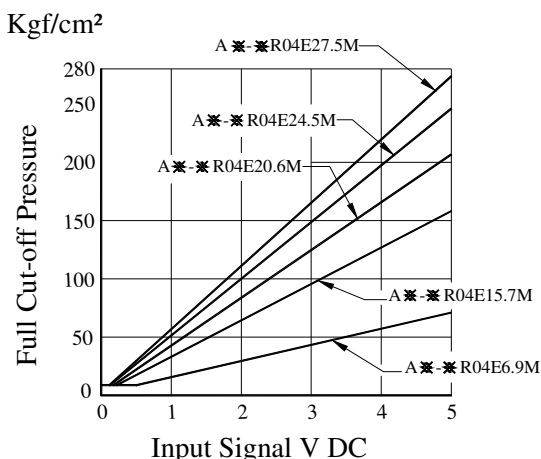

Refer to page 8 to 15 for performance characteristics of pressure compensator type excluding characteristics appeared on this catalogue.

A16-FR04E※-06-42

A22-FR04E※-11-42

● Flange Mounting

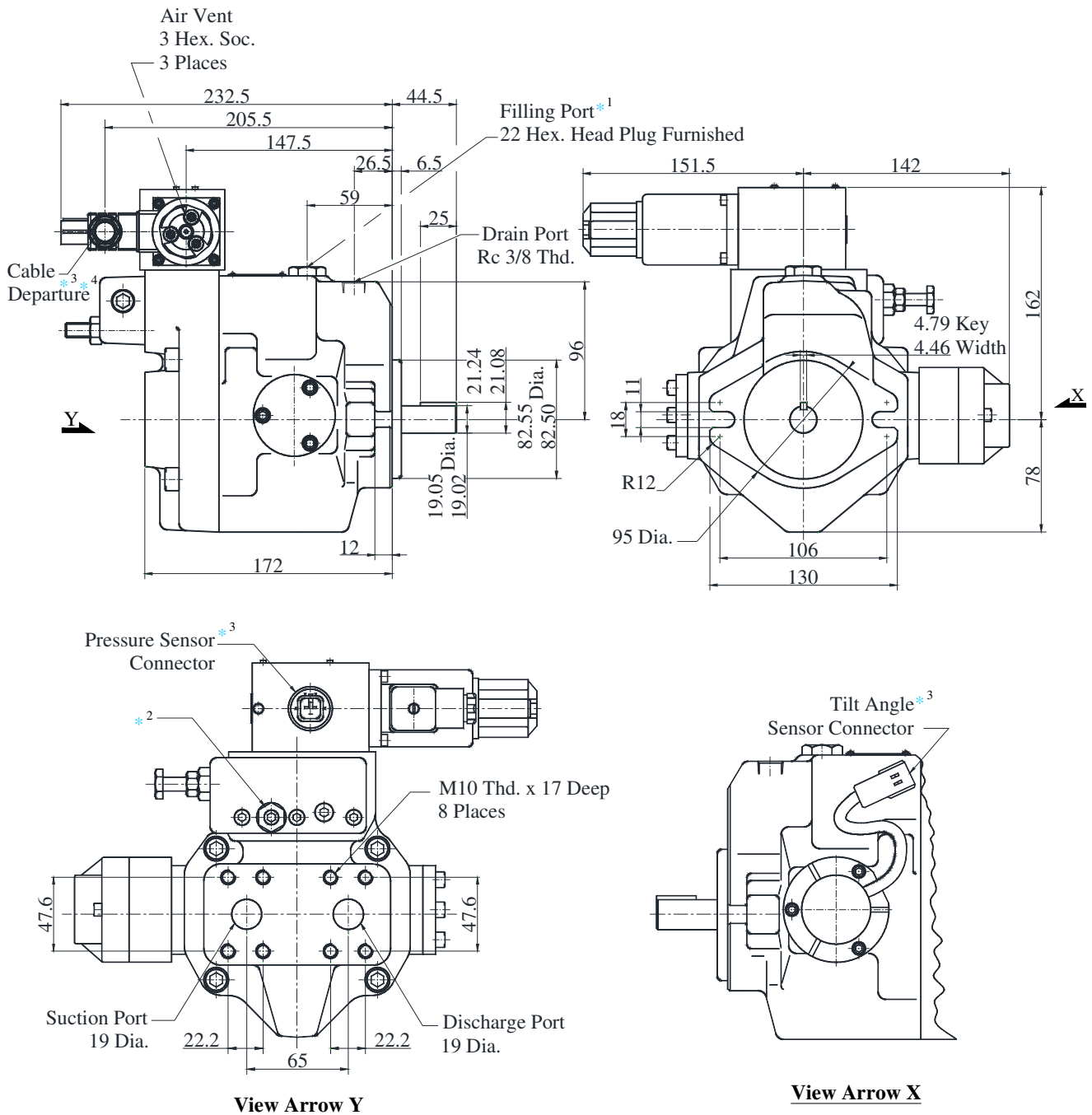

- * 1 Install the pump so that the “Filling Port” is at the top.
- * 2 Do not touch the screw because it is adjusted at the time of shipment.
- * 3 For cable connection with amplifiers, see page 44.
- * 4 Cable Applicable:
 Outside Dia. 8-10mm
 Conductor area Not Exceeding 1.5mm²

DIMENSIONS IN MILLIMETRES

● Foot Mounting type

Note : For Foot Mounting Type refer page no. 29.

“A” Series Variable Displacement Piston Pumps Single Pump, Electro-Hydraulic Proportional Pressure & Flow Control Type

A37-FR04E※-01-42

● **Flange Mounting**

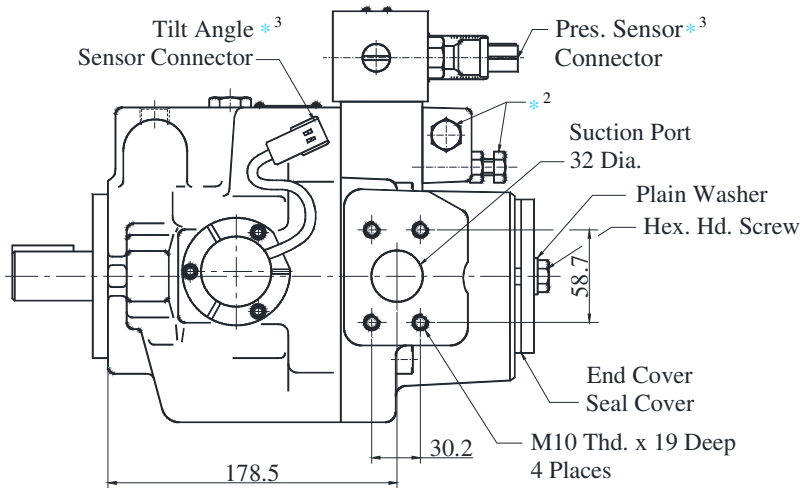
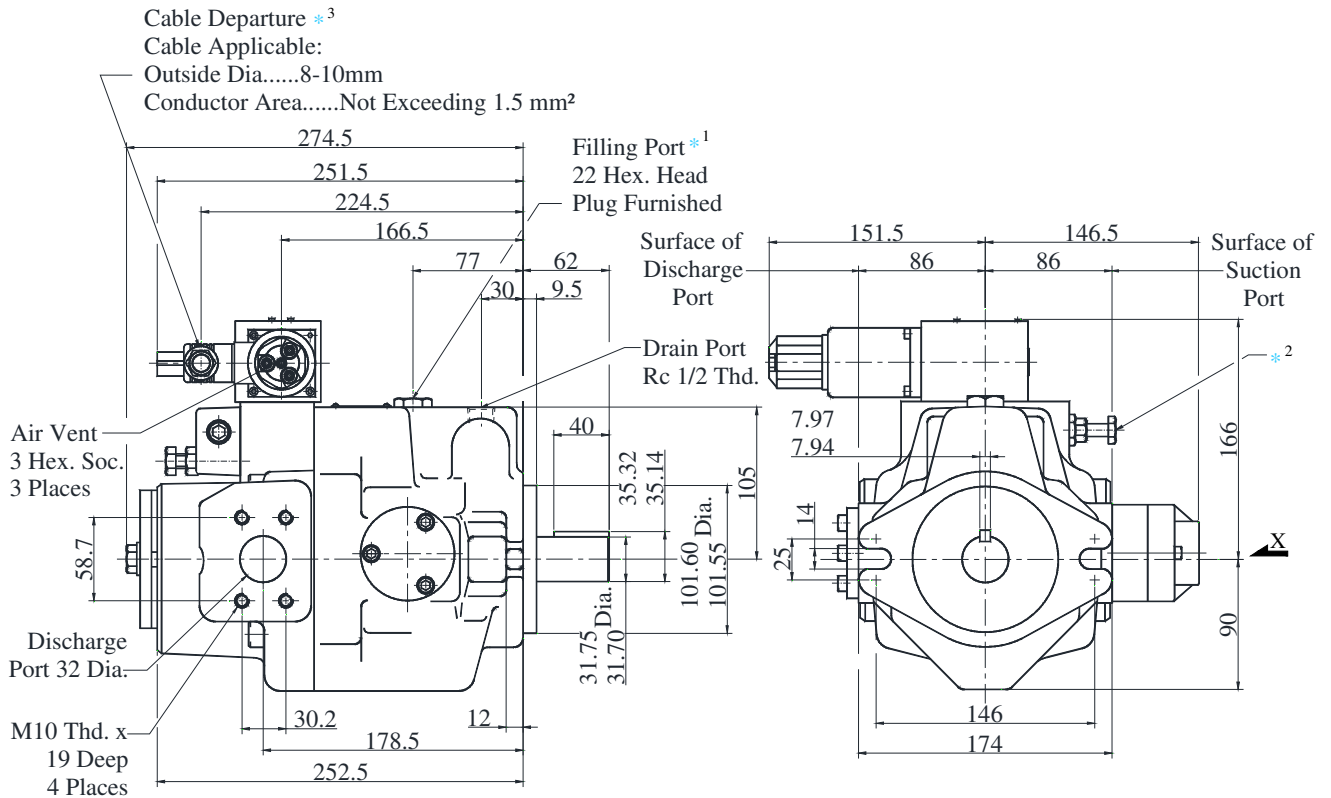

View Arrow X

- * 1 Install the pump so that the “Filling Port” is at the top.
- * 2 Do not touch the screw because it is adjusted at the time of shipment.
- * 3 For cable connection with amplifiers, see page 44.

DIMENSIONS IN MILLIMETRES

● **Foot Mounting type**

Note : For Foot Mounting Type refer page no. 30.

A56-FR04E※-02-42

● **Flange Mounting**

Cable Departure *4

Cable Applicable:

Outside Dia.....8-10mm

Conductor Area.....Not Exceeding 1.5 mm²

Air Vent
3 Hex. Soc. 3 Places

Filling Port *1

[22 Hex. Head Plug Furnished]

Drain Port *2

RC 3/4 Thd. (Both Sides)

Surface of Suction Port

Surface of Drain Port

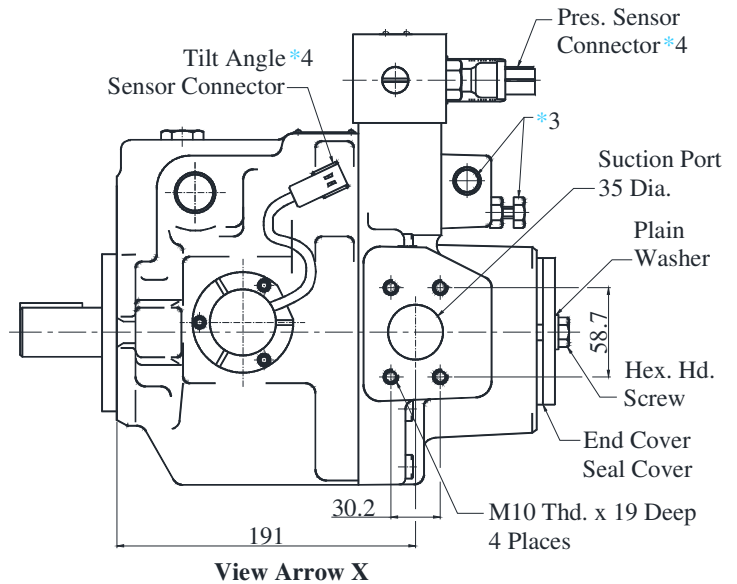
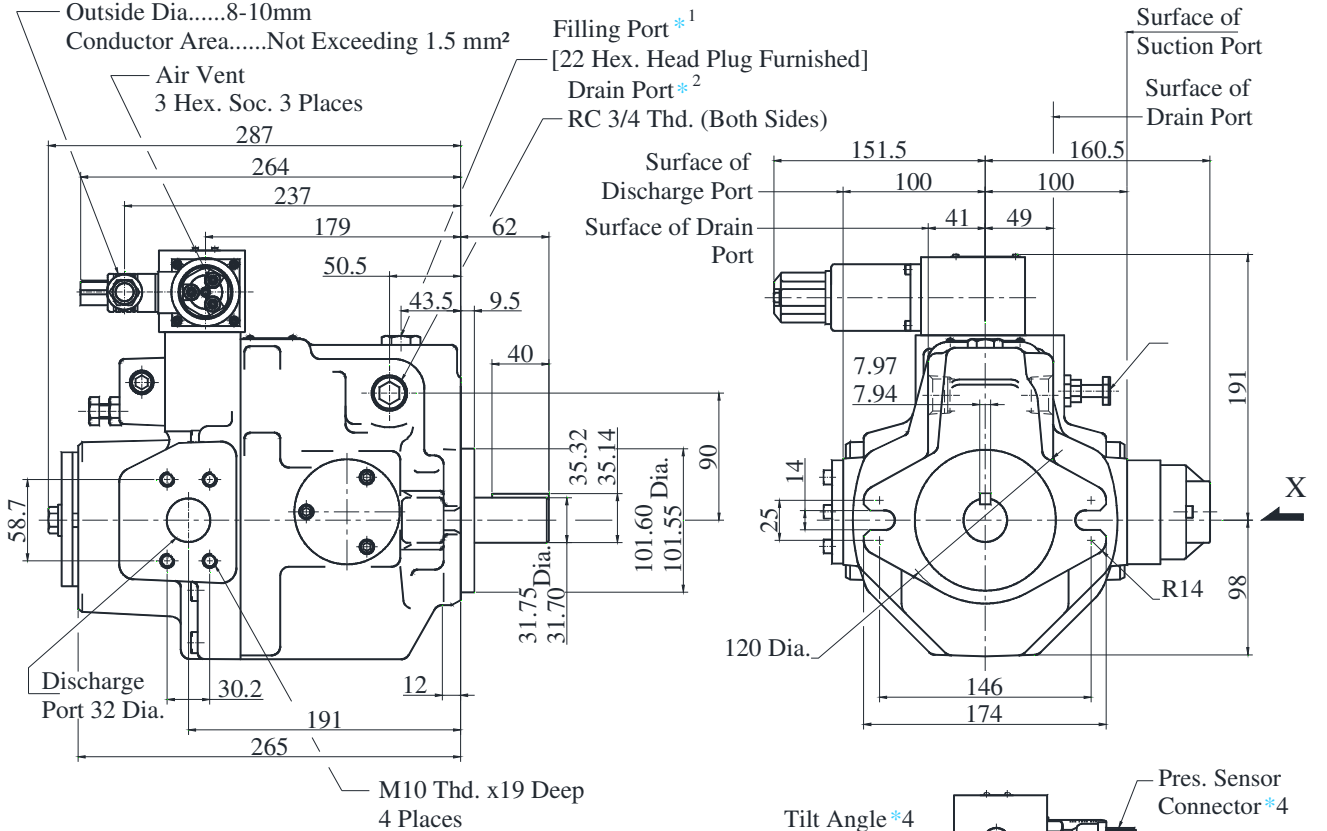

- * 1 Install the pump so that the “Filling Port” is at the top.
- * 2 Use either port of two drain ports at your option. Keep the remaining port plugged.
- * 3 Do not touch the screw because it is adjusted at the time of shipment.
- * 4 For cable connection with amplifiers, see page 44.

DIMENSIONS IN MILLIMETRES

● **Foot Mounting type**

Note : For Foot Mounting Type refer page no. 31.

**“A” Series Variable Displacement Piston Pumps Single Pump,
Proportional Electro-Hydraulic Pressure & Flow Control Type**

A70-FR04E※※-60-60

● Flange Mounting

Cable Departure *⁴
 Cable Applicable:
 Outside Dia. 8~10 mm
 Conductor Area Not Exceeding 1.5 mm²

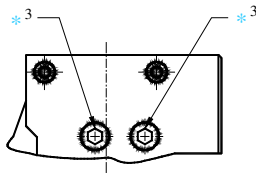
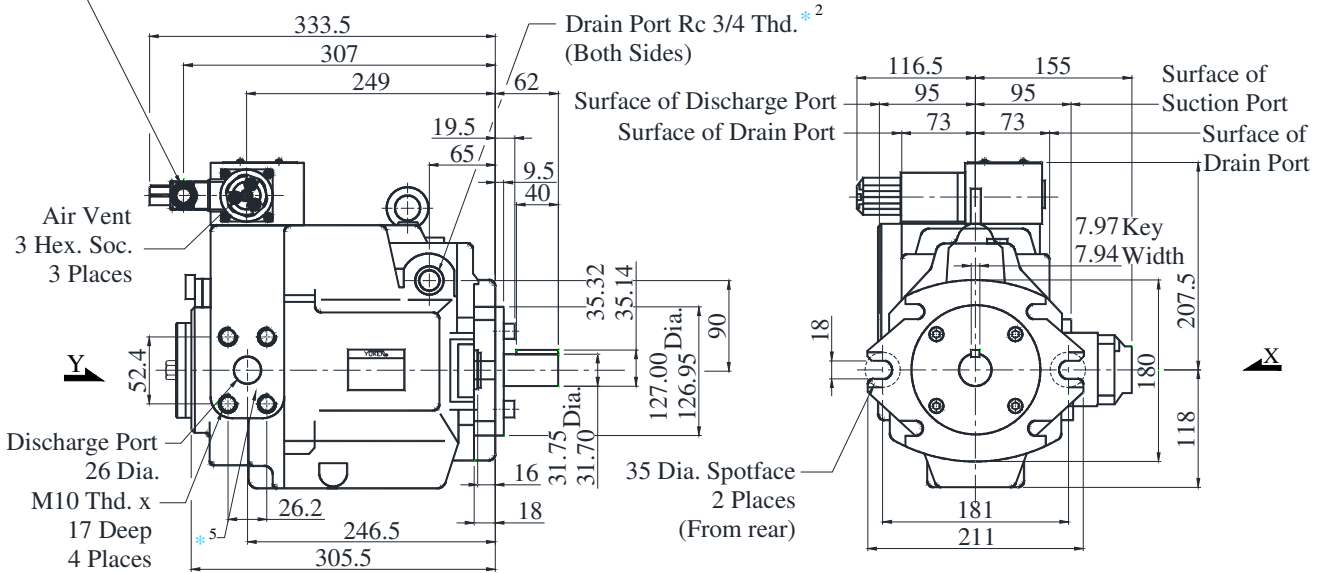

View Arrow Y

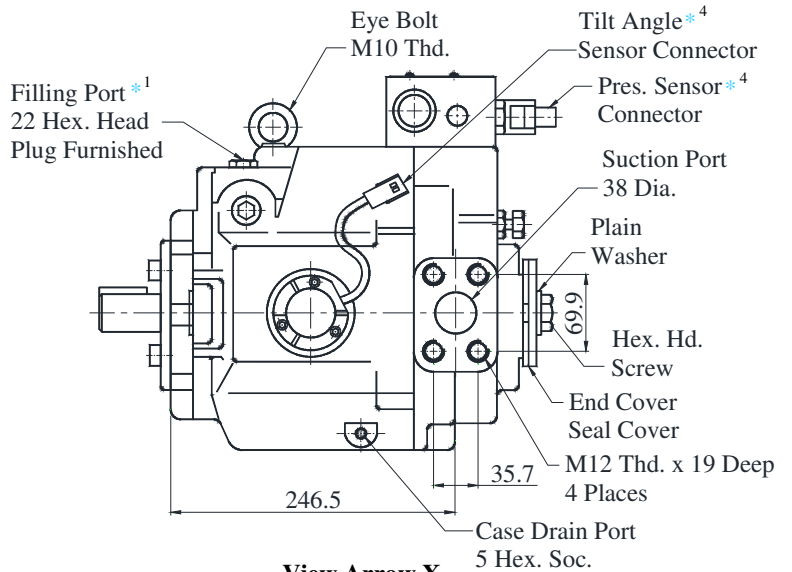

View Arrow X

- * 1 Install the pump so that the “Filling Port” is at the top.
- * 2 Use either port of two drain ports at your option. Keep the remaining port plugged.
- * 3 Do not touch the screw because it is adjusted at the time of shipment.
- * 4 For cable connection with amplifiers, see page 44.
- * 5 If you do not use the special sequence valve, plug the port (FP-SC-1/32)

DIMENSIONS IN MILLIMETRES

● Foot Mounting type

Note : For Foot Mounting Type refer page no. 32.

A90-FR04E※※-60-60

● **Flange Mounting**

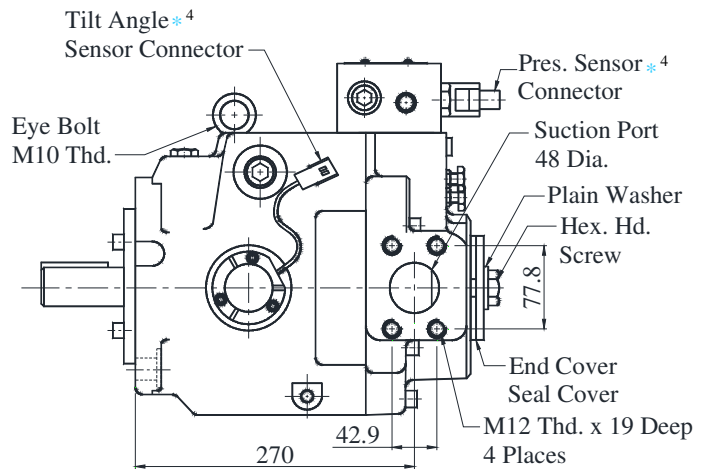
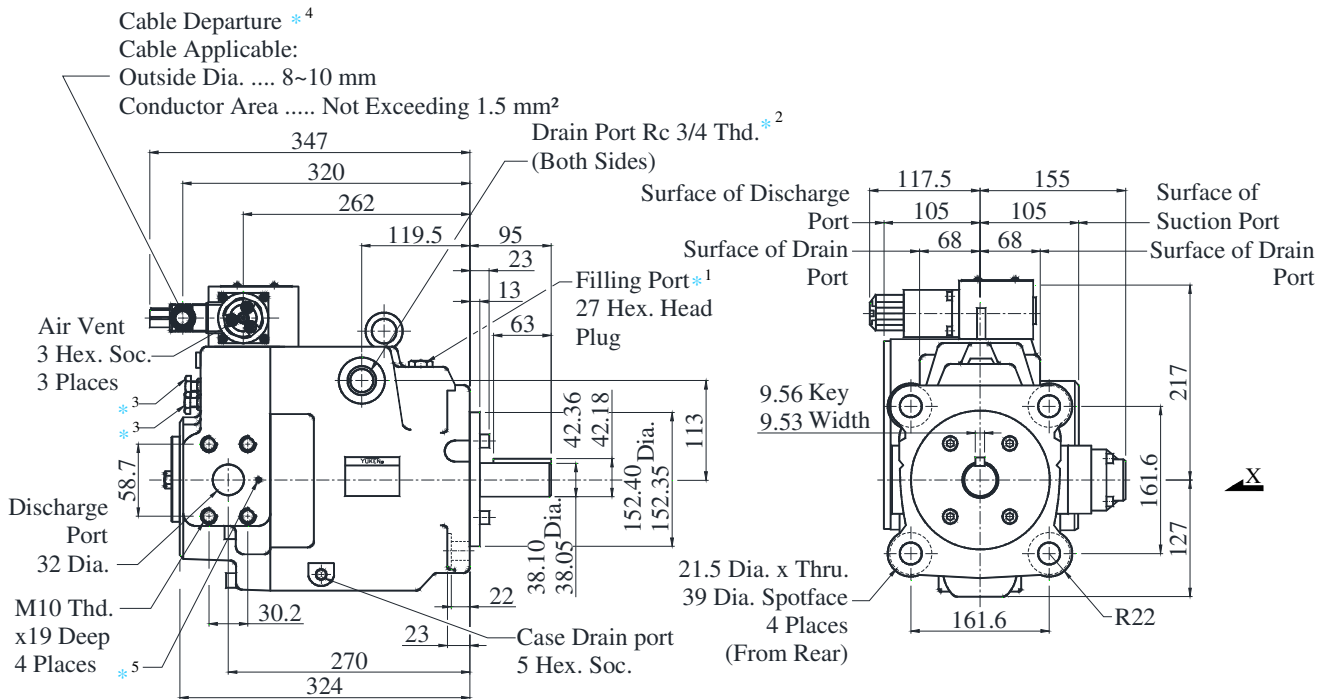

View Arrow X

- * 1 Install the pump so that the “Filling Port” is at the top.
- * 2 Use either port of two drain ports at your option. Keep the remaining port plugged.
- * 3 Do not touch the screw because it is adjusted at the time of shipment.
- * 4 For cable connection with amplifiers, see page 44.
- * 5 If you do not use the special sequence valve, plug the port (FP-SC-1/32)

DIMENSIONS IN MILLIMETRES

● **Foot Mounting type**

Note : For Foot Mounting Type refer page no. 33.

A145-FR04E※※-60-60

● **Flange Mounting**

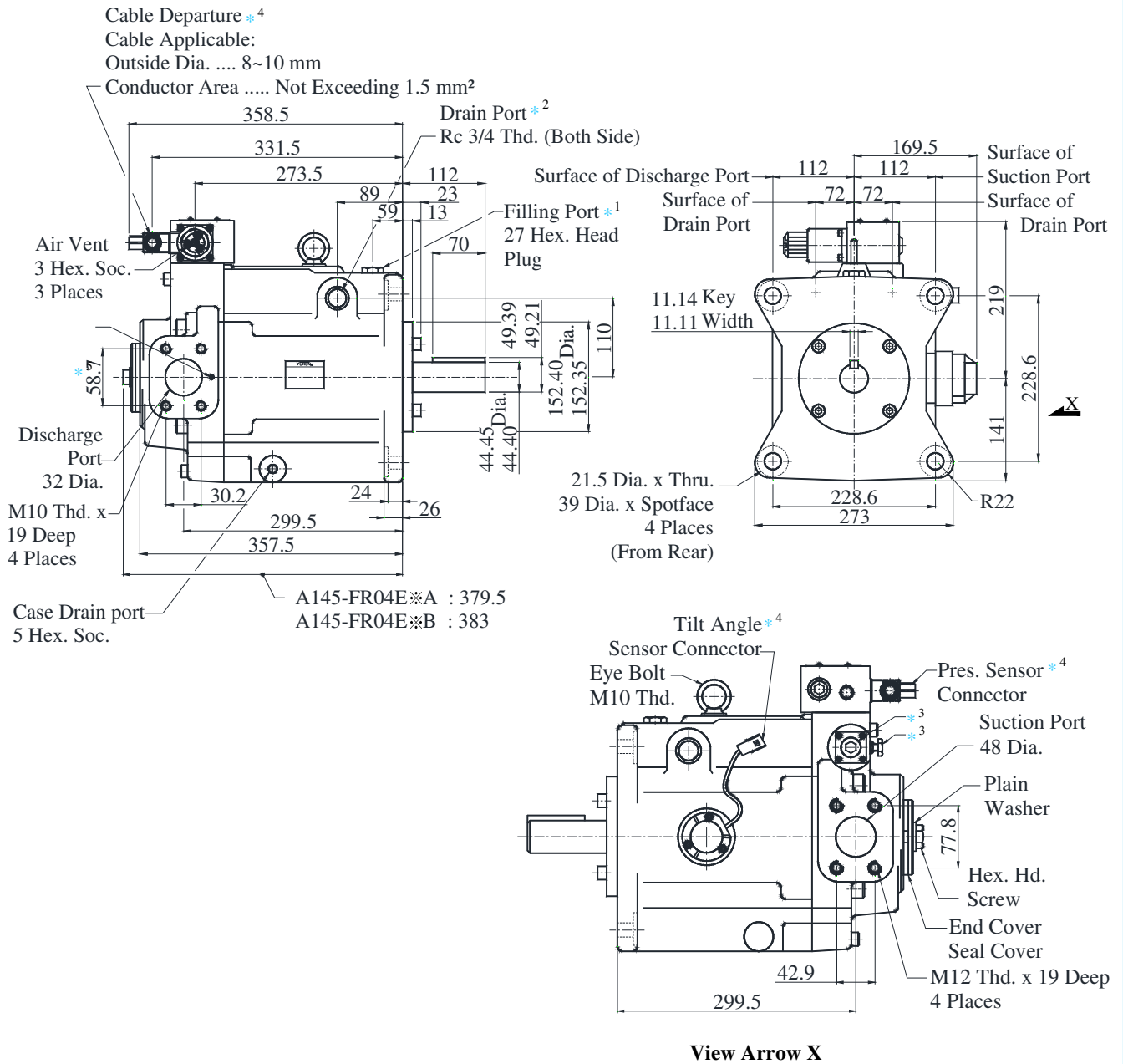

DIMENSIONS IN MILLIMETRES

● **Foot Mounting type**

Note : For Foot Mounting Type refer page no. 34.

- * 1 Install the pump so that the "Filling Port" is at the top.
- * 2 Use either port of two drain ports at your option. Keep the remaining port plugged.
- * 3 Do not touch the screw because it is adjusted at the time of shipment.
- * 4 For cable connection with amplifiers, see page 44.
- * 5 If you do not use the special sequence valve, plug the port (FP-SC-1/32)

■ Cable Connection between Pump and Amplifier

The cable connections between the proportional pilot valve and the sensor of the pump and the attached amplifier (SK1106) are shown below.

The cable assemblies are not included in the pump assembly. Purchase separately with model numbers described in the below table, if required.

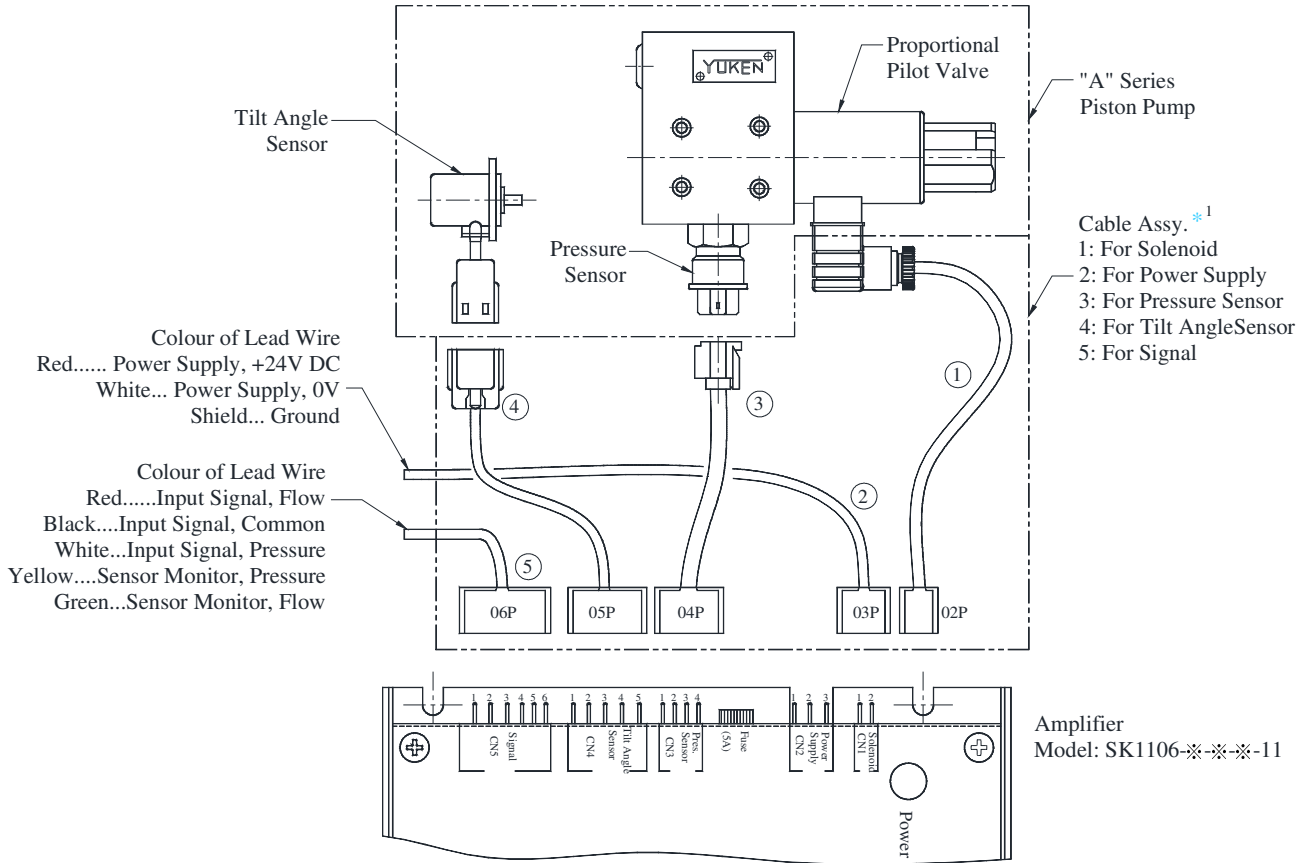

*1 Cable assemblies are available. When ordering, specify the cable ass’y model numbers from the table below.

Name of Cable Ass’y	Cable Ass’y Model Numbers		
	Approx. Length of Cable mm		
	2000	5000	10000
1 For Solenoid	SK1112-S-2-10	SK1112-S-5-10	SK1112-S-10-10
2 For Power Supply	SK1112-V-2-10	SK1112-V-5-10	SK1112-V-10-10
3 For Pressure Sensor	SK1112-P-2-10	SK1112-P-5-10	SK1112-P-10-10
4 For Tilt Angle Sensor	SK1112-Q-2-10	SK1112-Q-5-10	SK1112-Q-10-10
5 For Signal	SK1112-C-2-10	SK1112-C-5-10	SK1112-C-10-10

*2 For the details of amplifier, see the following page.

Amplifier for Electro-Hydraulic Proportional Pressure & Flow Control Type Pumps (SK1106-★-※-※-10)

Specifications

Model No.	SK1106-★-※-※-10
Description	
Applicable Coil Resistance	10Ω (at 20°C)
Input Impedance	10 kΩ (PIN, QIN)
Power Supply	24 VDC (21-28 V Included Ripple)
Power Input (Max.)	30 W
Input Signal	Max. Flow/5V (QIN), Specified Pres./5V (PIN)
Output Signal for sensor monitor	5V/Max. Flow (SMQ), 5V/Specified Pres. (SMP)
Ambient Temperature	0 - 50°C
Approximate Mass.	450 g

List of Amplifier Model No.

Pump Model Number	Amplifier Model Numbers
A16-※R04E★-06-42	SK1106-★-16-06-10
A22-※R04E★-11-42	SK1106-★-22-11-10
A37-※R04E★-01-42	SK1106-★-37-01-10
A56-※R04E★-02-42	SK1106-★-56-02-10
A70-※R04E★※-60-60	SK1106-★-70-60-10
A90-※R04E★※-60-60	SK1106-★-91-60-10
A145-※R04E★※-60-60	SK1106-★-145-60-10

Note: The symbol “★” shown with pump and amplifier model numbers, is the control pressure at input signal of 5 V.

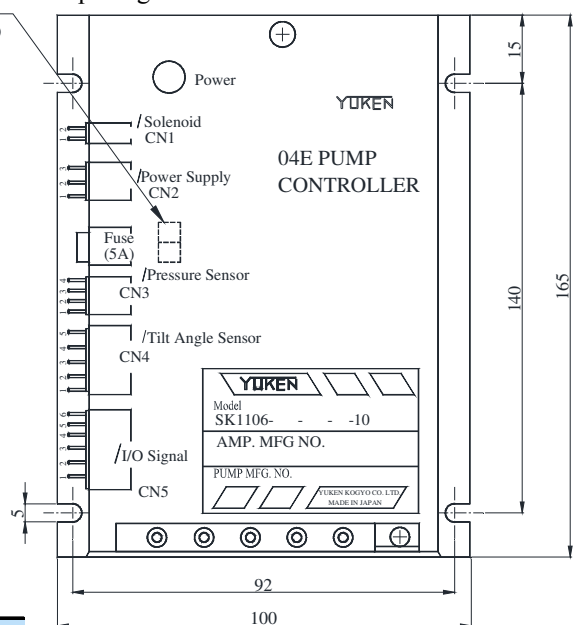
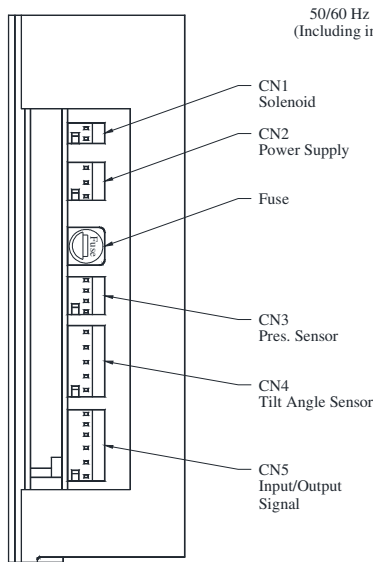

Detail of Connector

Connector	Name Of Signal		
CN1 Solenoid	1	Output to pilot valve solenoid	
	2		
CN2 Power Supply	1	0 [V] (0V)	
	2	+24 [V] (24V)	
	3	0 [V]	
CN3 Pres. Sensor	1	+5 [V]	Power supply for sensor
	2	0 [V]	
	3	Input Signal- Sensor	
	4	0 [V]	
CN4 Tilt Angle Sensor	1	+8 [V]	Power supply for sensor
	2	0 [V]	
	3	Input Signal- Sensor	
	4	0 [V]	
	5	----	
CN5 Input/output Signal	1	Input Signal-Flow (Qin)	
	2	Input Signal-Common (COM)	
	3	Input Signal-Pres. (Pin)	
	4	Output Signal-Sensor Monitor P (SMP)	
	5	Output Signal-Sensor Monitor Q (SMQ)	
	6	0 [V]	

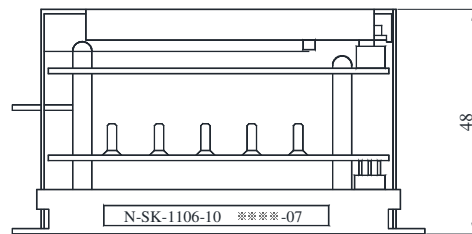

“A” Series Variable Displacement Piston Pumps Single Pump, Electro-Hydraulic Proportional Pressure & Flow Control Type